

UNIVERSITY OF PORT HARCOURT

***PRODUCTION – IT’S ALL ABOUT
NATIONAL DESTINY, BONDAGE
OR FREEDOM***

An Inaugural Lecture

By

PROF. JOHN UMUNNA OKOLI

[B.Sc (Nig.), Ph.D (Lagos), MNSE, MNIProd.E, ASME]

Department of Mechanical Engineering, Faculty of Engineering.

**INAUGURAL LECTURE SERIES
NO. 90**

JULY 26, 2012

ACKNOWLEDGEMENT

I deem it worthy to begin this acknowledgement with very hearty and immeasurable thanks to Almighty God who early in my life graciously illuminated my heart with a personal knowledge of Jesus as my Lord and Saviour. That singular event colored my life and saved me mercifully from the wayward path of youth.

I express my gratitude to the Vice Chancellor, Engr. Professor J. A. Ajienka for giving me the privilege to deliver this lecture.

My parents Mr. John U and Mrs. Belinda M. Okoli (of blessed memory) who sacrificed a lot to ensure my education deserve special and unequivocal thanks. I owe a lot to my elder brothers Ivan and Angus who provided a home for me when our father passed on. Basil and Chukwudi were an inspiration and made me realize early in life that I must face my studies and strive for excellence. Anene, Christiana and Dorothy bore my childish tantrums. The Christian family, Scripture Union, Nigeria Fellowship of Evangelical Students (NIFES), Nigeria Christian Graduate Fellowship and the Anglican Fold helped to cushion my life so that the rough bumpy ride of this world was minimal.

I owe a lot to my teachers in the primary school, in particular, Mr. Udoh, whose graphic painting steered me to Jesus as Saviour and Lord in 1959, Mr. Okeke spoke so commendably of Government College, Umuahia and this influenced my decision to study there. Mr. Stanley, as Headmaster, encouraged me to strive for excellence. At Government College, Umuahia the School under Chief I.D. Erekosima and Mr. S.B.Ogujawa made me to see that honesty, hardwork, and integrity should be the hallmark of my life. I remain grateful to all my teachers, prefects and friends at

Government College Umuahia, who helped to mould in me, the spirit of fair competition. Mention should be made of Chudi Okafor, Chikezie Okike and Chike Onyekwuluje.

Professor G. Ezekwe, who as Head of Department, Mechanical Engineering and Dean of Faculty University of Nigeria, Nsukka, found time to engage me in hands -on - activities in the workshop, inspired me to pursue a course in Design.

Dr.Okaisasor, as Director, NIFOR, threw the first challenge to me as an Engineer. I remain grateful to him. Mr. Austin Onyekwuluje and Dr. Okoye offered me early assistance in NIFOR. My colleagues in Agric Research Division, Engr. C. Ileche, Late Prof.O.Babatunde and Engr. Badmus, Late Engr. N. Digwo were of great help in my budding career.

I have been a beneficiary of Christian love, and owe a lot to the following; Uncle Dan Onwukwe, Uncle Tim Igwe, Obioma Okere, Enobong Iwokedok, Bayo Famonure, Eddy Onugha. Echi Nwogu, Frank and Nwakife Onuzo, Chibuzo Emmanuel, Bosa Okoli and Kola Ejiwumi.

Coli Fakinlade, Tunde Oladumiye and Chike Ezeani were a wonderful support whilst I was toiling in Lagos. Uchenna and Ngozi Mbajiorgu cushioned me when I relocated to Port Harcourt.

Of special mention is Late Prof.Chy Ikokwu, whose visits to me, at NIFOR, determined my coming to UNIPORT in preference to FUTO and Nnamdi Azikiwe University. My colleagues in the Department of Mechanical Engineering provided a sound base for my work. Of mention is the Faculty of Engineering where we work as a family. I cannot but mention the following who kept me company till late in the night while at work, (Late) Dr. N.Umesi, (Late) Prof. Chy Ikokwu, Prof. M.Ebong, Prof. Sam Ejezie, and Prof. I.L .Nwaogazie. My erstwhile office mates Professors. J.A.

Ajienka, and F. O. Chukwuma were good company. Prof. D.Appah and Prof. Adeyinka and Prof. A.O.Ibe, gave me invaluable advice when early in my sojourn, I was made the Acting Head of Department.

My wife Sophia has been an able adviser, counselor, trusted friend, objective critic and helpmate. My children Tochukwu, Chiamaka and Nwachukwu bore the brunt of my many absences from home, and when in my early career the dining table would be littered with drawing instrument and papers.

I thank Ven. (Prof.) W. O. Weneka, who made me to settle and integrate into Emmanuel Anglican Church, Okoro nu Odo. The other pastors and priests who served in the same church deserve my thanks. My In-Laws, the Ifezulikes have been a wonderful lot and deserve special thanks for rallying to assist my family in times of need.

Gladys Madu, Dorcas Iheanacho, Tobinson Briggs and Raymond Webilor assisted in various ways in preparing this write up. I thank my numerous students who have been ‘human guinea pigs’ in my design and production engineering classes.

Numerous are those who have been a blessing to me. Space and time does not permit me to mention all of them. Thanks to all of you.

PRODUCTION – IT’S ALL ABOUT NATIONAL DESTINY, BONDAGE OR FREEDOM.

Introduction

The Inaugural Lecture is expected to serve as an opportunity for the Professor (the newly crowned Professor) to tell the public in a lay-man's language, what he/she professes, the contributions made, problems encountered (including man-made ones) and the prospects for the future. In doing so, there is the risk that it may not be easy for the lay-man to understand some of the technical terms the Professor may inevitably have to use in order to justify being a specialist. It is my plea that you bear patiently with me, should you find some aspects of this lecture too pedantic or too boring in the course of its delivery.

Mr. Vice Chancellor, I thank you for this opportunity. I am happy and will have a feeling of fulfillment when this assignment is completed. Then I will as in the Holy Scripture take a deep breath and say “It came to pass”.

The first inaugural lecture from the Faculty of Engineering was in the year 2000 by Professor Chy Ikoku (of blessed memory) of the Department of Petroleum and Gas Engineering. It was titled “Petroleum: Mankind’s Best Friend”. There have been others from the same department and also from Civil and Environmental Engineering Department. This is the first from The Department of Mechanical Engineering. I believe that after this the flood gates will open and my colleagues in the faculty will rise to the challenge and thrill the University, nay the country, with their contributions to the betterment of our common heritage.

Mr. Vice-Chancellor, I profess Mechanical Engineering, but my specialization is Design and Production

(in some climes Production is also called Manufacturing). Since I ply my trade in this area, please allow me to use terms in this field. I shall strive to be as simple as possible in order not to bore the expert in an attempt to accommodate the novice.

Mr. VC, design and production engineering depend a lot on lines. Architects and artists are also in the business of 'lines'. For the design and production engineer lines constitute a means of communication. They are a means for creation. The architect from his imagination creates buildings and their environments by means of lines on paper, in addition he applies shades to amplify his creation. This creation of the architect is then transformed by the engineer to real life *static* monuments. The creation of the architect is always static and he needs an engineer to realize his imagination. When 'quacks' are employed, buildings they put are bound to collapse, as has been the case in Abuja, Lagos, Ibadan, Enugu, Awka etc in recent times. The artist equally uses lines, but profusely shades the drawing to bring into manifestation the creation of his mind. The artist's creation 'remains' on paper, canvas, wall or board, it is still/static, it is lifeless, however it can come alive in the beholder's attempt to read the mind of the artist. It is one's ability to read/decode /interpret the mind of the artist that determines the worth of an art piece. So it is not uncommon to find that the work of an artist could be given as many interpretations as are the beholders. In so doing none of these beholders is 'injured'. The design /production engineer does not enjoy such luxury. His creation with lines must at all times be given one and only one interpretation. You may wonder why this should be the case. The reason is simply that the creation on paper by the design engineer is usually transformed into physical objects and devices by the production engineer. The creation of the design engineer is given 'life' by the production engineer. Any misreading of a line would lead to a

wrong product, hence wastage. You can understand Sir, why the work of the design/production engineer is very critical to the society. The automobiles, bicycles, etc on the roads; aeroplanes in the air, ships in the water and diverse equipment used in homes and offices are the creation of the design/production engineer. These products of the engineer, diverse as they are, help man to have a hold on and to master his environment. In this, we note that the engineer is fully in compliance with the mandate of God to man in Genesis 1:28-“... Replenish the earth and subdue it and have dominion over the fish of the sea and the fowl of the air and over every living thing that moveth upon the earth”

The design engineer communicates by means of lines, and in some cases adds sentences, many times in coded form, to amplify what should be done to a given piece of material in order to give it ‘life’. Figure 1 presents some lines used by the design engineer. The implication is that a wrong line in a wrong place speaks disaster during production.

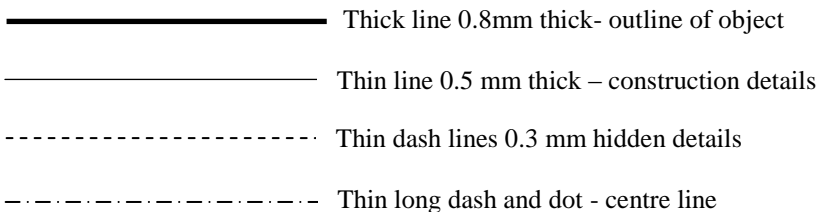

Figure 1 Lines and its meaning

Machines and other equipment are the output of the imagination of the design/ production engineer. Typically each machine consists of many components, just like humans - the God made machine, has so many parts, some of them like, kidneys, liver, lungs, intestines etc hidden inside the body, so it applies to the creation of the engineer. A machine may have just two components as in the simple case of a lever

mechanism which is visible and could also have tens of parts as shown below.

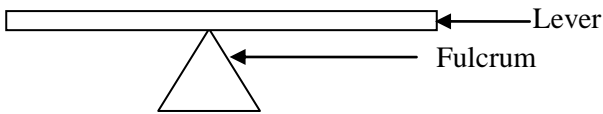

Figure 2 Two member and multi-member mechanisms

Each of these parts must be carefully considered and designed so that they work in synergy.

VC Sir, you can then understand why the design engineer must be a very creative mind.

Let us take, for instance, the human eye. The eye lids slide without ache or discomfort over the eye ball, because there is a lubricant which the glands in the eye secret to cushion the rubbing effect of the eye lids over the eye ball. In a similar manner many parts rub and slide over one another in machines. The engineer knows that mating parts encounter friction and generate heat, the resultant effect is wear followed by seizure. To ameliorate this, lubricants are applied. The right type of lubricant must be applied to ensure the parts function

properly. That is why there are grades of lubricants for automobiles. Any car owner who is ignorant of this pays dearly for it.

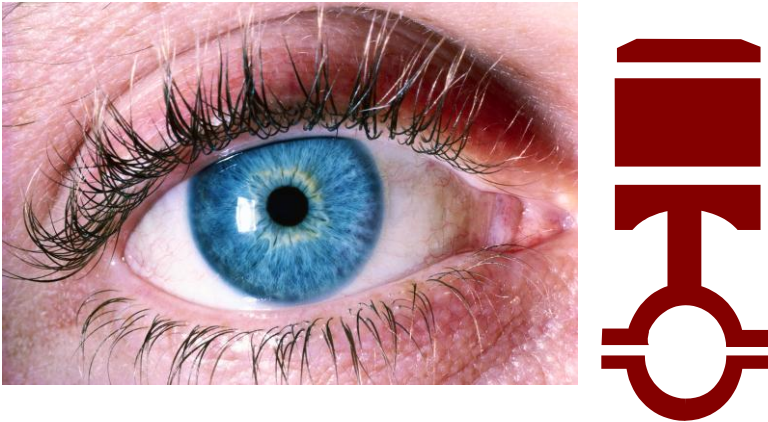

Figure 3 Human eye and piston

Many of you here own cars and do appreciate that the right type of engine oil has to be put into your car engine on a regular basis. The engine oil lubricates the internal walls of the cylinder within which the piston moves. Should this be neglected the resultant effect is engine knock which of course will sideline the car for a period of time, and only a deep slice in your pocket to satisfy the mechanic revives the car again.

Engineering Process

What is engineering? Engineering is concerned with the application of scientific knowledge to the solution of problems and to the quest for a 'better life'. In so doing he/she applies this objective knowledge to the creation of plans, designs, and means for achieving the desired objective. In its effort to solve problems, engineering provides feedback to science in areas where new knowledge is needed. Thus science and engineering work hand in hand. Often a high degree of

creativity is required in order to proffer solution to the problems and needs of the society. The creative steps taken can be categorized simply as analysis and synthesis. In analysis the object (problem) is broken into its basic elements, whereas synthesis involves putting the basic elements together in order to get a new or improved system (Turner et al 1978; Parker, 1989). The engineering process is schematically presented in Figure 4. The iterative nature of the engineering process is portrayed by the two opposing arrows in the figure between the blocks representing analysis and synthesis.

One stage of analysis provides sufficient insight to postulate a particular design. This design, in turn, provides additional information that changes the basis of the analysis. This iterative process is repeated until an acceptable solution, system or method is derived (Turner et al. 1978).

Acceptable is used instead of optimal because a true optimal design is rarely achieved. The limitation of assumptions under which a particular design is made determines the degree of its optimality.

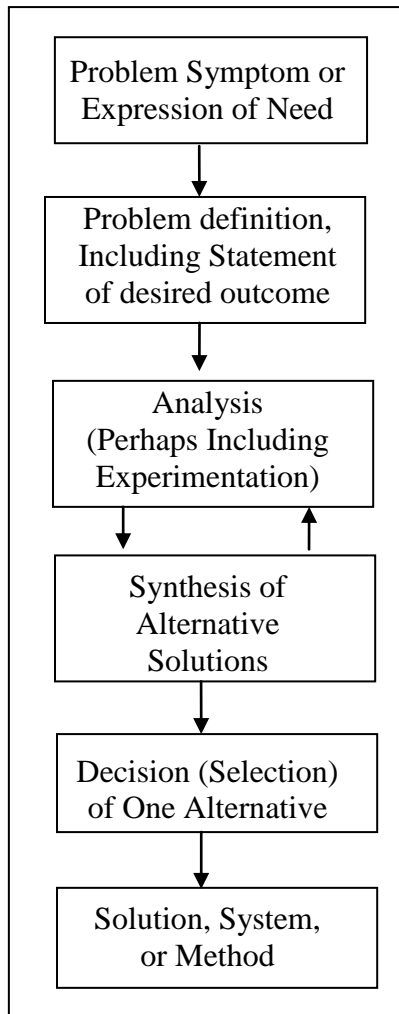

Figure 4 Basic engineering processes (Turner et al., 1978)

Mechanical Engineering

Mechanical engineering turns energy into power and motion. Mechanical engineers design, create and improve systems and machineries that are used for domestic, public and industrial purposes. This area covers the design and manufacture of a great variety of products such as domestic appliances, industrial machinery, ships, aircraft, engines, pumps, compressors and turbines or complex systems such as the air-conditioning and ventilation systems of buildings. The mechanical area interlinks closely with other areas of engineering and basic sciences and applies knowledge of materials, energy and structures, it harnesses knowledge of human behavior and economics for product design; determine conducive man-machine environment and ensure the feasibility for production. Figure 5, presents these links. Mechanical engineering design and production/ manufacturing are subsets of mechanical engineering.

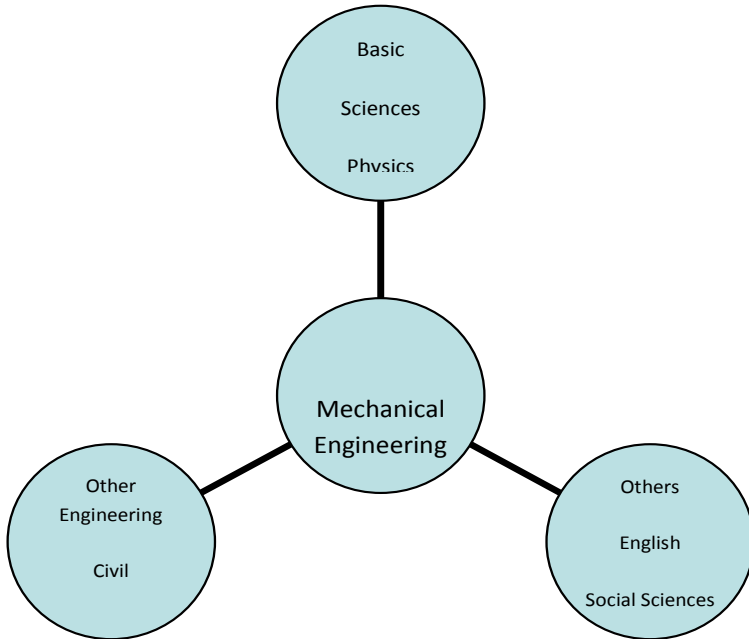

Figure 5: The making of a Mechanical Engineer

Relationship between design and manufacture

Companies cannot afford to hold rigidly to given products; rather they continually develop new and improved products because no company can remain commercially viable if it remains static. It either grows or dies. The future product requirements of the society and their specifications are determined by the sales and marketing departments who keep contact with other competitors in the market place. However, the technical responsibility for producing the detailed specifications necessary for making these new products lies with the design department. Figure 6, is a simplified flow chart for making items from existing ones. Designers must basically consider the implication of their designs on manufacturing cost. A sound knowledge of manufacturing processes is a basic

requirement for this. Thus the application of the principle of 'design for manufacture' is necessary for any product designed to be successfully implemented by the production engineer.

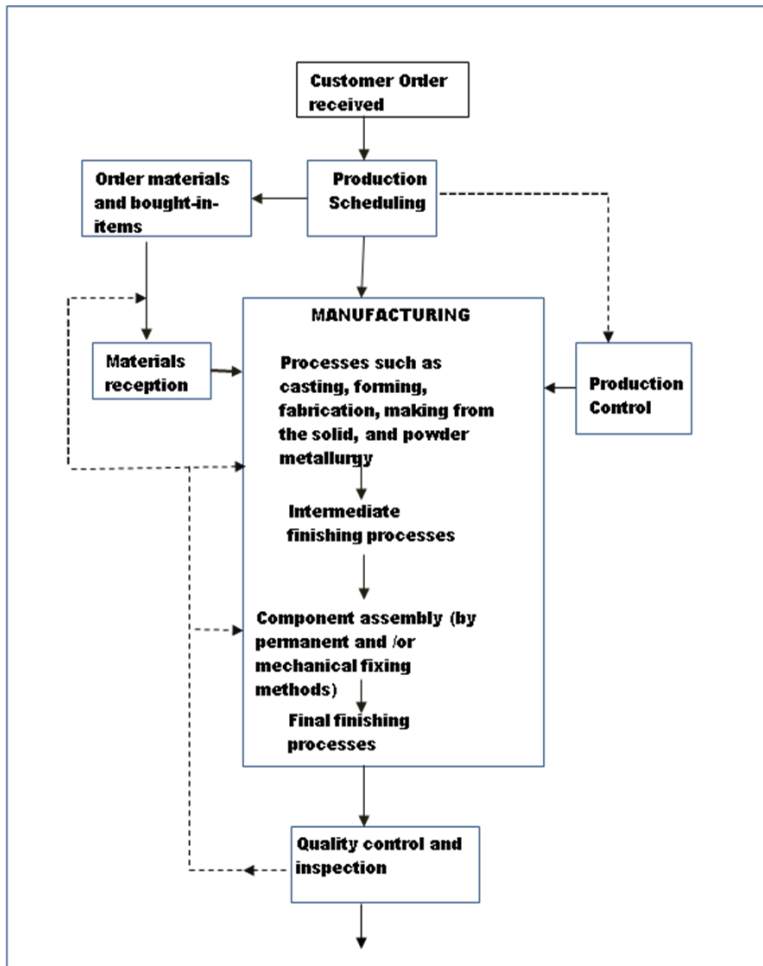

Figure 6: Typical flow chart for making engineering items from an existing product range

Definitions

It is appropriate to define some key terms of common use in engineering design and production.

Manufacturing Engineering / Manufacturing systems engineering is concerned with the processes and systems that are used in industry. Systems and equipment that complete tasks accurately and change raw materials into products with the smallest wastage of time, materials and energy systems are designed and improved by manufacturing systems engineers.

Production Engineering is the design and application of manufacturing techniques; it includes activities such as (i) planning, specification, coordination of the use of resources, (ii) analysis of productivity, production processes and systems, (iii) application of methods, equipment and tooling, (iv) controlled introduction of engineering changes and (v) application of cost control techniques.

Design is the realization of a concept or idea into a configuration, drawing, model, pattern, plan or specification (on which the actual or commercial production of item is based) and which helps achieve the item's designated objectives. It is reasoned decision making which captures and translates the images in the mind to physical objects (Chestnut, 1965, Gosling, W. 1962, Okoli, 1997).

Design basis is a set of conditions, needs and requirements taken into consideration in designing a facility or product.

Design capacity is the quantity or volume of material a plant or facility is designed to process.

Design conditions are the environmental conditions to which a design will be subjected and internal conditions which will be required to be maintained at specific levels for the design to serve its purpose.

Design defect this is the frailty or short coming of an item resulting from a defect in its concept, and which can be avoided only through an alteration of or redesign of the item.

Industrial Revolution

In order to capture the spirit of this lecture, it will be necessary to go on the history lane. In so doing we recall the industrial revolution (IR). The industrial revolution of the 17th century was as a result of technology change. Technology is defined as the branch of knowledge that deals with industrial arts, applied science and engineering, or the sum of the ways in which social groups provide themselves with the material objects of their civilization (Blanchard and Fabrycky, 2006). The islands of England metamorphosed into the kingdom of England in the tenth century, while England and Scotland formed the Union of Great Britain in 1625 (Carrington and Jackson, 1954). During the period of more than 1000 years of nationhood, the productivity of the peoples of the region was reflected by primitive tools like hoe, axe and draught-oxen (Davis, 1969). Britain achieved the first real industrial revolution in the period 1770-1850 (Gregg, 1971). Thereafter the nation achieved economic diversification, productivity increased dramatically and manufacturing became prevalent with decreasing proportion of the population in agriculture.

The industrial revolution brought about the substitution of people for machines. The process affected the nature of work left for people to do. Cottage industries dependent on handcraft were displaced, and in their place were machines which did the same work at faster rates, with greater accuracy

and at cheaper runs. The machine tools invented and in place were manipulated by fewer people who were able to produce the equipment and artifacts needed to oil the economy of the nation. More people were released to engage in other fruitful endeavours. The producing nation (then Britain) had the advantage of exporting its goods, produced under very competitive costs to other needy nations. This increased its wealth creating ability, because it had more money with which to pursue the growth of technology.

Technology growth is change stimulated by an attempt to respond to some current unmet need and/or an attempt to perform an ongoing activity in a more effective and efficient manner. The British in response to their need designed and built machines which oiled their industrial growth and transformed their economy from agrarian to industrial status. A primary agent for transformation in the industry is the machine tool which is used for producing factory equipment. The British developed their machine tool industry and with it built a series of machines and equipment with which their emerging factories processed primary goods into finished goods at cheap and highly competitive costs. With these goods they dominated world economy in the eighteenth, nineteenth and early twentieth centuries; their goods were and are still available all over the globe.

Other nations of the West principally Germany and France followed the trend and developed their machine tool industry. Consequently they had high manufacturing ability, and could produce quality goods at cheap and competitive costs for export, in response, their economy soared.

These nations devoted their effort to the training of men, skilled in the art of design of machinery and equipment with which to convert natural resources to finished and marketable goods needed by the society. It involved disciplined and thoughtful planning, proper management and

application of resources. On the other hand the Scandinavian and Mediterranean nations pursued the path of commerce with vigor, their attention was not primarily focused to technology advancement. It is worthy of note that the nations that were foremost in acquiring colonial territories were Britain, France and Germany. This they did because they had goods to export, and also needed assured territories from which they could get natural resources for their factories with unhindered ease. Some Mediterranean also had colonial territories too, but on a limited basis, they were enmeshed in commerce.

America and Industrialization

Whereas it took over a thousand years after its existence for Britain to achieve industrial development, America adopted a different strategy to achieve this goal in much shorter period. America, after its war of independence in the period 1775-1783 (Baldwin, 1969), developed an entirely new culture and a language to express it. America placed emphasis on the formal, liberal and technical education of its citizens, so that in just about a century it achieved industrialization compared to the thousands of years it took Europeans. America had become a world power by the first half of the twentieth century. America is a world power because of its strong education system and great manufacturing strength. Whereas European and Asian nations have hundreds of universities, America has thousands of degree awarding institutions (Johnstone, 1985).

Classification of Countries

In relation to scientific and technological development, one generally accepted classification of countries today is that which says that there are three types of countries. These are namely; the technologically advanced countries (TACs), the newly industrialized countries (NICs) and the developing countries (DVCs). The TACs are in the West, the nations in

Western Europe (United Kingdom, France Germany, France, Sweden, Italy etc and North America and some parts of Asia. The NICs are Taiwan, Singapore, Indonesia, India, Brazil, etc. The DVCs are in Africa, Latin America and Asia. You now know where Nigeria belongs.

In the emerging global economy, the wealth of a nation is no longer determined by mere possession of natural resources, but largely by the technological capacity to add value. Ability to transform the natural resources into products which are acceptable and globally competitive defines the wealth of a nation. The TACs and NICs have technology. Japan has very limited natural resources, so do Taiwan and Britain but they import raw materials and transform them to products needed by the society and thereby create wealth for themselves. Japan has no iron ore, yet it ranks as one of the major steel producing countries in the world. On the other hand Nigeria has abundance of natural resources, iron ore inclusive, yet it remains poor. Poor countries are dominated by wealthy ones who dole out aid packages with which these poor ones are attached to their apron strings, and are thereby forced to do their biddings.

One way of objectively assessing a nation is by doing a survey to determine the volume of locally produced goods in the market. In a typical Nigerian super market, a conservative estimate is that about ninety percent of the goods are imported. The made in Nigeria goods are limited to construction material, clothing, textiles, footwear and processed foods which are produced using simple assemble processes. This scenario is of course very unhealthy for the economy.

MACHINE TOOLS AS DRIVER OF INDUSTRIALIZATION

The foundation for industrialization could be traced to the development of a practical steam engine at about 1700; this

displaced the ox as a primary source of power and led to the development of mechanical devices which it could drive. These devices which were able to work and form metals, particularly iron and steel, into diverse products were now harnessed onto the steam engine. Thus, the machine tool came into being.

A **machine tool** is any machine operating other than by hand power which employs a contact tool for working natural or synthetic materials. A machine tool is characterized by the following: it is a capital item because of its relatively high purchase cost, it is not consumed by the product for which it is built, other than through normal wearing of its moving parts, it has useful life up to ten years and longer, (Dallas, 1976). A **machine tool** is a machine for shaping or machining metal or other rigid materials, usually by cutting, boring, grinding, shearing or other forms of deformation. Machine tools employ some sort of tool that does the cutting or shaping. All machine tools have some means of constraining the workpiece and provide a guided movement of the parts of the machine. Thus the relative movement between the workpiece and the cutting tool (which is called the **toolpath**) is controlled or constrained by the machine to at least some extent, rather than being entirely "offhand" or "freehand" (Wikipedia, June 2012).

Examples of conventional/traditional machine tools include but are not limited to the lathes, milling machine, drilling machine, shaper, jig borer, table grinder and gear cutter. They are characterized by chip formation and swarfs from the stock material (Figure 7). **Equipment and small tools** supplement the work of the machine tool. **Equipment** means transfer mechanisms, fixtures, and jigs usually employed in moving or positioning the product for operation by the machine tool. Small tools include contact tools such as forming, forging, and

drawing dyes, and consumable tools such as drills, taps, reamers, lathe tools and other tools for material forming or removal. Equipment and small tools are usually characterized as expense items on company books. Equipment is not ordinarily consumed during manufacture, but is directly related to the particular product or style of product being made at a given time and hence subject to quick obsolescence, generally, it is not capitalized. Contact tools such as dies are consumable to a degree, and small tools such as metal cutting tools are consumable to a high degree.

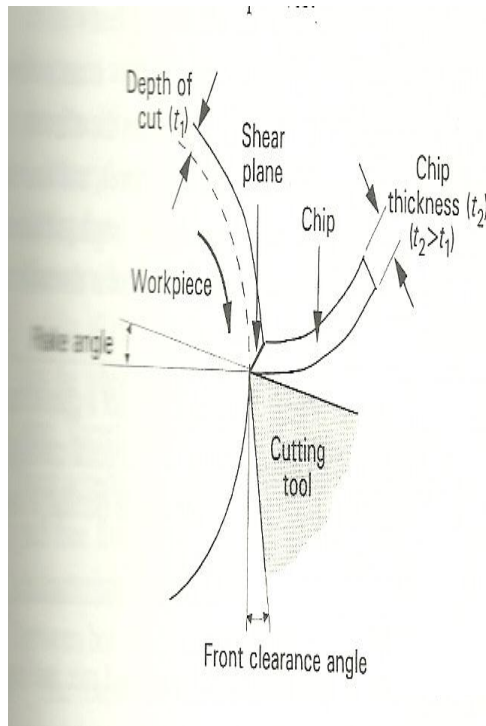

Fig 7a Cutting tool Produces swarf



Fig 7b Grinding centre

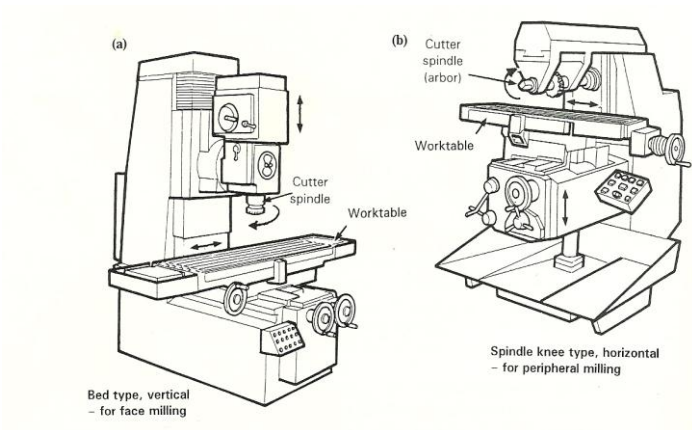

Fig 7c Vertical and horizontal millers

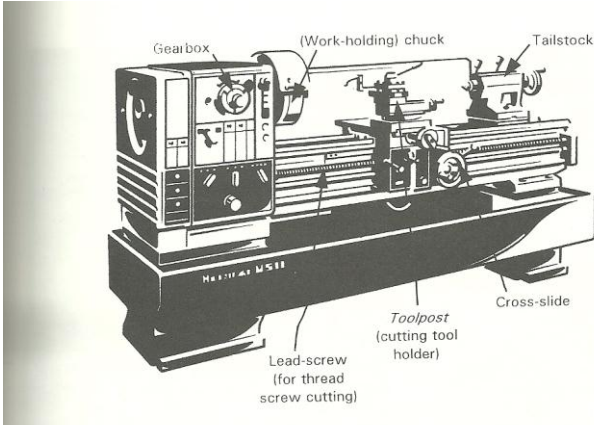

Fig 7d Centre lathe

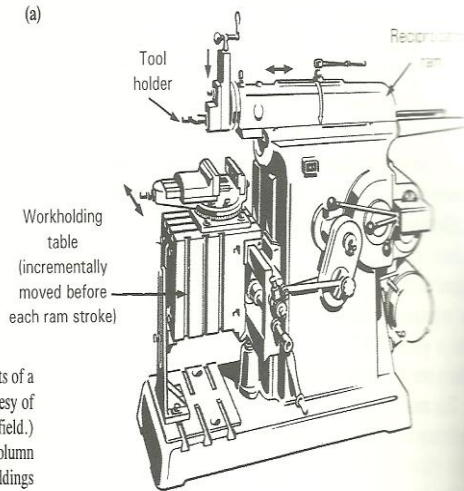

Figure 8.6 (a) Elements of a shaping machine. (Courtesy of Buck & Hickman, Sheffield.)
 (b) Large double-column planer. (Courtesy of Giddings & Lewis Ltd, Prescott.)

Fig 7e Shaping Machine

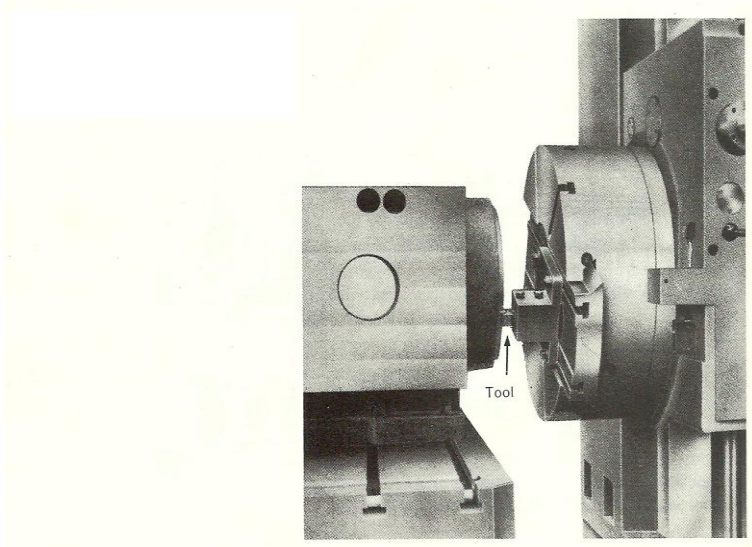

Fig 7f Horizontal Borer

The complex role that machine tools play in the standard of living of a society is subtle and pervasive. It is difficult to imagine a product that has not been made by a machine tool or made by a machine which has in turn been made by a machine tool. Machine tools are essential to nearly every conceivable industry- aerospace, automotive, electronics, agriculture, housing, including the defense of a nation. Figure 8 captures the pervasive nature of the application of the machine tools, and its consequent influence on the standard of living of any given society.

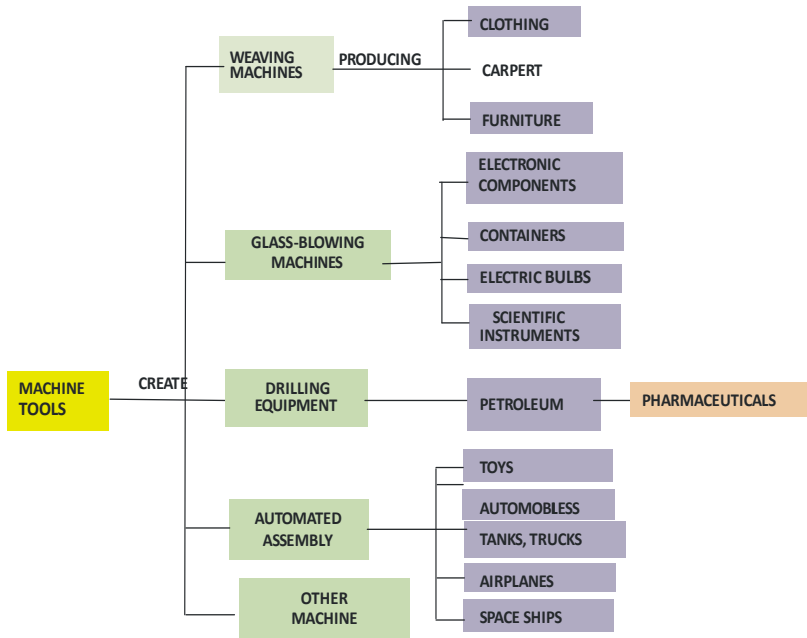

Figure 8 Deployment of machine tools

The all important position of machine tools to industrial production, and invariably in advancing the economy and social stability of a nation; and assuring its territorial integrity can best be shown by the following summary (Dallas, 1982b) of the contribution of America production to war effort during World War II.

War planes	...	296,429
Tanks and self propelled guns	...	102,351
Artillery pieces	...	372,431
Trucks	...	2,466,946
Warships	...	87,620
Cargo ships	...	5,425

Aircraft bombs (tons)	...	5,822,000
Small arms	...	20,086,061
Small arms ammunition (rounds)	...	44 billion

Developments in machine tool technology

Machine tools can be powered from a variety of sources. Human and animal powers were used in the past, as well as water power. However, following the development of high pressure steam engines in the mid 19th century, factories increasingly used steam power. Factories also used hydraulic and pneumatic power. Many small workshops continued to use water, human and animal power until electrification after 1900 (Hunter et al, 1991)-. Machine tools can be operated manually, or under automatic control. Early machines used flywheels to stabilize their motion and had complex systems of gears and levers to control the machine and the piece being worked on.

When steam engines became the vogue after the mid 19th century, belts were coupled to steam engine driven line shafts that ran overhead through the entire length of the factory. The steam engines were positioned at the end of the factory. The harnessing of the shafts to machine tools required the deployment of several clutch mechanisms and gears for the engagement/disengagement of the machines whose function may/may not be needed at any given time during the operating hours of the factory. One fundamental weakness of this system was under utilization of the power generated by the steam engine because all the machines never operated all the working hours of the factory. Another weakness was the safety implication; overhanging belts could cut and pose danger to operators. Furthermore, the belts required repeated tensioning, and this posed challenges to productivity.

Internal combustion engines later replaced steam engines, and with the development of electric motor; these

were now coupled to provide direct drives to the machine tools in the late 1920s and early 1930s which paved the way for increased power input and compactness. Other trends were increased use of antifriction bearings, use of heat treated alloy steel gears and spindles, alloy cast irons for beds and columns, hardened steel ways, covered ways, light alloys for reciprocating members, large feed and speed dials, forced-feed lubrication larger coolant reservoirs, and larger tanks to maintain oil for hydraulic systems at the right temperature (Dallas, 1982a). Increasingly machine tools were built of weldments rather than as machined castings and electrical controls began to supersede the hydraulic controls used for table movements.

There were radical changes in the design of crank and camshafts which led to the development of precision grinding machines of size, power and range otherwise considered impossible. Automatic electric sizing devices that stops the grinding wheel forward and provide a dwell period and then back to the work were incorporated in grinding machines.

In the year 1934, two significant technological advances were made in external broaching and the application of centreless principle in internal grinding. Broaching lathes are now available for industry application and auto industry applies broaching for finishing flat surfaces. The technology of contour band sawing which was developed in 1935 had the impact of drastically reducing production time for tool and die-making in the press- tool industry. A bench lathe larger than the usual run is equipped with anti-friction bearings for the spindle and transitorque drive with the motor which was mounted on a variable speed control device was developed in 1936.

The year 1938 evidenced a deliberate change in machine tool design which incorporated electric controls. This

added to increased flexibility of machine tools. A machine tool capable of cutter speeds of 183 ms^{-1} obtained from a redesigned spindle, driven hydraulically was developed in 1944, this meant improved productivity. In this same year the principle of shock absorption was adapted to cutting tools equipped with high-speed or tungsten carbide tips. A thin copper sheet inserted between the tip and the tool shank was a cushion and acted as shock absorber for varying loads applied on the cutting edges during machining.

A shaper lathe was introduced in 1945; this was essentially a tracer lathe in which a three-dimensional form, e.g. a mould could be duplicated. Its design incorporated a sophisticated tool control system. In this same year a new concept in hole punching - the C frame units which could carry die sets and produce holes according to set patterns proved to be a highly effective form of short-run tooling.

Dallas (1982b), summarized the requirement of machine tool as viewed in 1946 as 'compactness, to save valuable floor space; ease of operation and maintenance, to compensate for a growing shortage of skilled workers; more rigid construction; control of thermal expansion, greater use of electricity, greater accuracy; ability to preselect a cutting tool's finishing cut dimensions, and more special purpose machines'. This had in view an ideal machine which could perform all operations on a work-piece. The machine would combine many dissimilar operations, yet it would be made sufficiently flexible to take care of periodic changes in product design. In this year ENIAC (electronic numerical integrator and computer) the first all-electronic general computer was built, this laid the foundation to the present day computer applications in design manufacturing and indeed all areas of life. Other developments include lathes with indexed electronic turrets that could change speed automatically, an automatic chucker with a mounted dummy turret that could be used to set

up tooling for the next job. Precision and boring machines with fully automated chuck-type, internal grinders carry multiple spindles and gear making machine capable of making 'roto-shaving' a process that was used to achieve close tolerances on laminated motor rotors which was previously achieved with up to two turning operations and a final grind.

Quick change lock for spindle tapers permit seating and ejecting of shank-type cutters, arbors and adapters without use of draw keys and drifts were introduced into boring machines in 1948. The shank of the tool was simply inserted into the spindle opening then a small screw for seating was tightened. A wedge action held the tool securely. Tungsten carbide began to find wide use in blanking, piercing and deep drawing dies because thermal expansion was not a problem with the material, so that accurately sized punches and dies could be made with typically produced parts of outstanding finishes.

Stamping found wide use in 1949 because it lend itself to high degree of automation, in consequence, about fifty percent of automobile parts were produced by stamping, besides parts that were originally made of forged machine components were redesigned for stamping application. Non destructive testing method by ultrasonic inspection device which could locate defects and inclusions and determine whether the bonds were good in laminated materials found application in industry. A quartz- crystal based probe sent out on high frequency (ultrasonic) waves into the material being checked and the progression of the waves were observed on a viewing screen called an oscilloscope. It quickened the method of quality checks on factory products.

The machine tools of 1950 were heavier, more rigid and provided higher spindle speeds than their predecessors. Higher speeds implied live centers and arbor support on mills. Vibration dampers were incorporated in the milling machines to reduce chatter. Also developed were automatic screw

machines and chuckers with attachments that permitted multiple operations in a single chucking. More powerful electric motors were deployed for milling cutters; and hydraulics found increasing use for driving rams of presses, the heads of drilling and honing machines and tables of planers. A typical machine featuring these advances was a single-spindle bar machine tool. It featured a five-slide indexing turret and three angularly mounted cross slides. Since they were all independently actuated, multiple operations could be performed. Each of the turrets was controlled by cams on a drum in the headstock, and each of the headstock slides was operated by disc cams located under the slides, consequently the movement of all eight could be readily synchronized, which reduced machining time.

Electrical discharge machining which involved chipless material removal from the

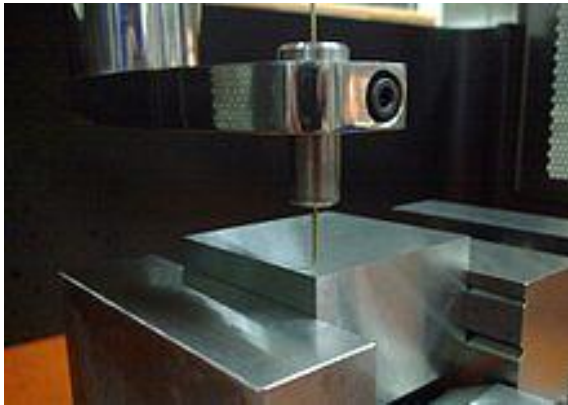

Figure 9a Small hole drilling EDM machines



Figure 9b A turbine blade with EDM made holes

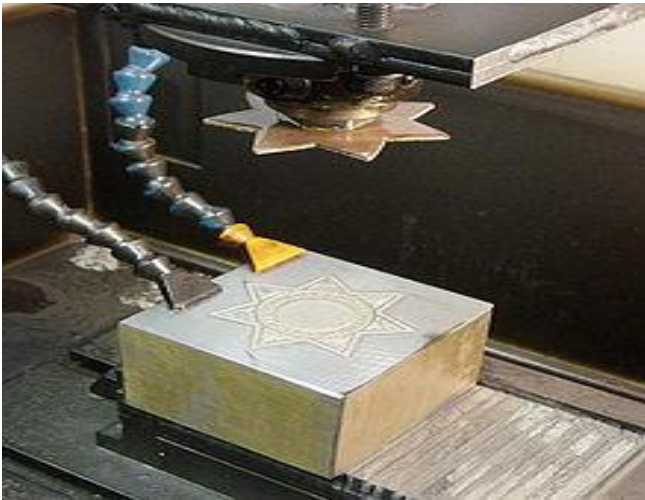

Figure 9c Master at top, badge die workpiece at bottom

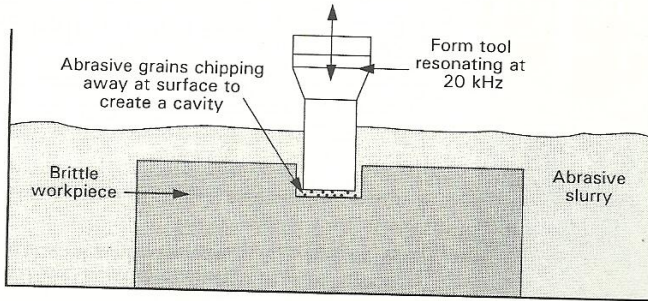

Figure9d Basic Principle of ultrasonic Machining

feedstock found industry application in 1951. This was the foundation for modern non-traditional/non-conventional machine tools which have now made it possible for very intricate shapes to be cut on extremely hard materials. Examples of these machine tools include (figure 9); electrical discharge machining (EDM), electron beam machining (EBM), laser beam machining, plasma arc machining, electrochemical machining (ECM).

Machine tools designed to perform contouring, boring, turning, facing, grooving, and rabbeting on large circular parts emerged in 1952. Increased use was being made of electronic controls in machine tools. Electronic motor control was used to rectify the ordinary a-c power to supply d-c power thus permitting use of d-c motor for machine tool drive. Variation of current supply to the armature or the field ensured speed control; potentiometers served this purpose. The benefits of electronic motor control include infinite number of speeds within the motor's range, rather than a number limited by gears. Speed changes could be effected without stopping the machine; and the

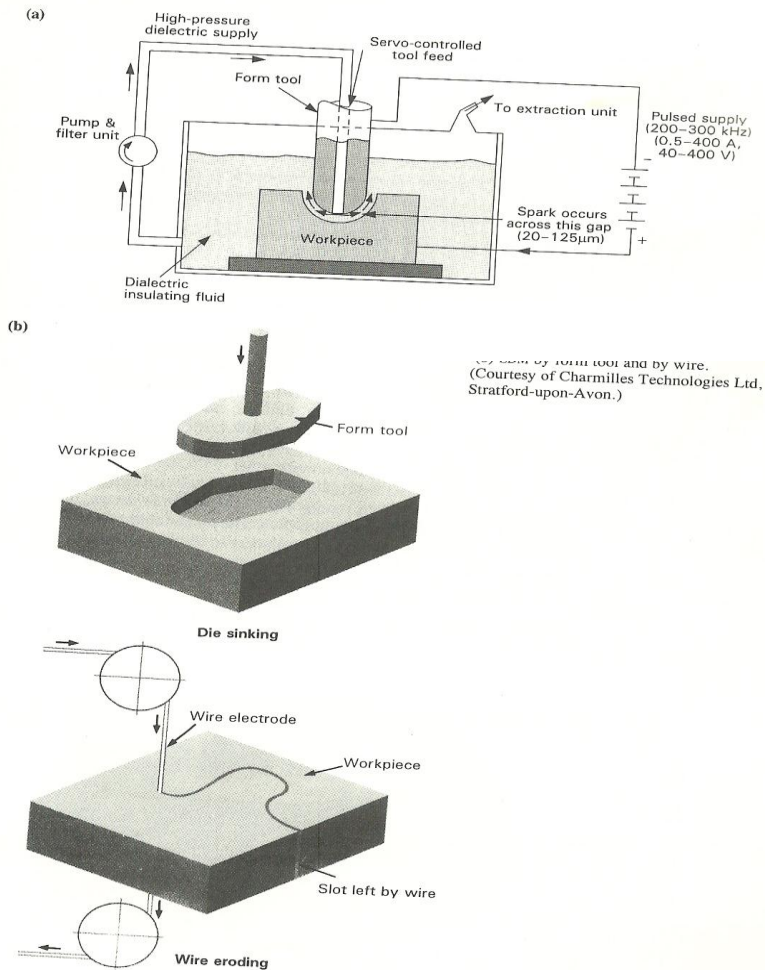

Figure 9e (a) Basic principle of Erosion (b) EDM by form tool and wire

capability to set up automatic operations in which the feed speed changes. Application of electronics in the area of automatic reproduction was used to cut down production time drastically. Production operations which conventionally took months to accomplish could now be done in a matter of days.

A formal demonstration of the numerical controlled machine milling was conducted in September, 1952 by the Servomechanisms Laboratory. The data on punched tapes coupled the automatic control system for the first axis of milling that was completed in July 1951 to those of the second and third axes to produce the required product in one continuous operation of the machine tool.

The years 1954 to 1959 witnessed cutting advances in conventional and nontraditional machining methods. Machine tools equipped with sophisticated numerical control driven devices and the emergence of machining centers was the vogue. In 1959 APT (automatically programmed tool) was developed as a 107 – word – (no word longer than six letters) language that would be utilized by a part programmer to write a programme data from an engineering drawing. This data would be punched into cards that would be loaded into a computer, which would then generate the punched tape to run a machine tool. If a design change was desired, then a card or few cards would be replaced; the computer would handle the variations. High programming speed, shorter lead times, and accurate tapes were benefits of APT. Electron beam, electrical discharge machining (EDM) and electrolytic machining processes had now made its way effectively into industries.

The period 1960 to 1969 evidenced numerical control moving forward as prices of its application dropped and computers proliferated in the industry. Computer aided design had its beginnings in 1964 and in 1968 computer numerical control (CNC) found its way into the industry, and cut the overall lead time drastically. In addition to shorter lead time, the rate of hole production speeds up to 72 per minute. A conventional press could do only 30 to 40 holes a minute (Hartwig 1982).

The period 1970 to date has witnessed incredible advances in machine tool technology. Machine tools that are

completely computer driven and robot operated have made their way into the industry. This has paved the way for complete automation of manufacture.

A consideration of how the economy of a nation is influenced by the contribution of machine tools to national production will be taken.

ROAD TO INDUSTRIAL TRANSPORTAION

Economic world view to transformation

Economists identify factors of production as land, labour, capital and enterprise. They also investigate their relative contributions to growth. Such researchers and scholars as Charles Cobb and Douglas (1928), Douglas (1948) Abramowitz (1956) and Solow (1957) investigated the relative contributions of capital (K) and labour to growth and found that labour contributes more to growth of output than capital. Abramowitz and Solow showed that about 90% of the growth of output per head in the American economy during the late 19th century through to the first half of the twentieth century could not be accounted for by increase in capital per head. The lopsided importance which this study attributed to non-capital input in determining production output was a disappointing finding to economists because they have been brought up to believe that capital accumulation and investment play a critical role in achieving sustainable economic growth and industrialization (SEGI) (Thirlwall, 1972). Abramowitz advised economists to look somewhere else from capital in search of the source of sustainable economic growth and industrialization.

Economists would not relent in their belief that mere capital investment promotes growth. To justify this Romer (1986), defined capital to be the composite of physical and human capital. This belief that capital investment promotes

growth remains the fundamental premise of economic planning and management in the world today. This derives from the fact that evolutionists (August Comte, William Summer, William Spencer, Vilfredo Pareto, etc) and neo-evolutionists (Ferdinand and Tonnies, Emile Durkheim, Max Weber, Talcot Parson, etc.) had theorized that Western Europe in the sixteenth century had achieved the maximum level of human development for societies. The authors then classified nations into two categories simple (primitive) and complex (advanced) (Hoogvelt, 1976).

The nations classified as primitive were Africa, Asia and Latin America, whereas nations in the West were classified as the advanced ones. The evolutionists and the neo-evolutionists then proposed that primitive people and places may be made modern by transferring resources, especially technology from the West to them. This is the origin of International Technology Transfer (ITT) which is being pursued today with vigor to the chagrin of DVCs. The modernization theorists set out to operationalize the evolutionists and neo-evolutionist theories. These are manifest in the efforts of the World Bank and the International Monetary Fund (IMF).

It is will be necessary to determine the degree of transformation of the DVCs by the massive aid of the TACs over the past three decades. Have the DVCs not continued to wallow in poverty, political doldrums and technological backwardness? Obviously then ITT has not proved to be a viable solution.

My experience with an aid programme

A relevant question would be ‘who really benefits from the aid packages?’ To answer this question, I will narrate my experience. Upon graduation as a young engineer in the mid nineteen seventies, I was employed by a foremost Research

Institute, the Nigerian Institute for Oilpalm Research (NIFOR), Benin City. I was deployed to the Agricultural Engineering Research Division, which was a fledgling unit being built up under the UNDP/FAO partnership. The sponsoring nations were Britain, Belgium, France and Spain. The international staff were from Britain (Project Manager), Belgium (Design and Testing Engineer), and France (Process Engineer). The project was aimed at developing oil palm processing capacity for the oil palm belt of Nigeria. The implementation mode was directed at equipment design, fabrication, process development and testing. The machine tools and other equipment of the project were entirely purchased from Britain, and Spain. In executing the project, a Nigerian counterpart staff could not ride in any of the project vehicles except in the company of the UNDP expert staff. No equipment for the project could be purchased from Nigeria with the project fund; all purchases from the project fund had to be from the donor nations. I was aghast. Work would be held up to wait for orders of equipment from donor nations, whereas those items were available here and at cheaper prices. It was an eye opener. Technical aid drives the economy of donor nations; because they provide the project staff and the equipment must be purchased from their prescribed vendors. Local staff deployed to the project are paid by counterpart funding by the benefitting nation. Permit me to use a common Nigerian quote; I may be faulted in not acknowledging anyone. 'The hand of the giver is always on top'. Therefore, the donor nations will always be on top, because they keep building up their capability. You can now assess the true worth of diverse aid packages. International Technology Transfer is a tool for keeping the receiver ever on the begging platform. Otherwise, I challenge you to name a developing nation which has with the much touted ITT achieved industrialization.

Knowledge and skill acquisition

If a country is blessed with huge national resources of minerals and oil, it should be possible to guarantee a high standard of living for its people. This can be attained either by buying all the products and services or by establishing a solid production base of its own. Some countries of the Middle East with vast oil resources are a good example of the adoption of acquisition; United States is a prime example of the latter. Ogbimi (2004) has developed a model which confirms the American model for industrial industrialization as a viable option. He asserts that the objective of the learning person appreciates with learning time and learning intensity. Consequently, whereas all capital assets are depreciating assets, the learning-people are appreciating assets. Hence the objective value of the learning- man may be modeled by the growing function;

$$M_n = M_o (1+r)^n \quad (1)$$

Where: M_o is the initial objective (intrinsic) value of the learning man

M_n is the intrinsic value of the learning-man at time $n = 1, 2, 3 \dots n$, and r is the learning rate or intensity. He presented a composite plot of $(1 + r)$ vs, n at three levels of $r = 1\%, 5\%$, and 10% ; and explained why Western and Eastern nations toiled for years before achieving modern industrial revolution. It took them that long because learning was neglected for that long. That is, the learning rates in those societies were low. In all learning processes, the learning rate determines rate of progress. Education facilitated a rapid development in the United States because they invested purposefully and generously in this sector (Baldwin, 1969).

Other works of Ogbimi (2010) developed the variables for planning for industrialization and great manufacturing strength. He showed that as N , the number of people learning in a nation increases, a point is reached where each knowledge,

skills and competences in the society form knowledge, skills and competences framework an invisible problem attacking front. Then the economy is transformed, it achieves industrialization (technology puberty) and economy diversification. Productivity increases dramatically and reliable infrastructural network is developed as a fruit or aftermath of technology puberty. The economy is transformed, it achieves industrialization (technology puberty) and economy diversification. Productivity increases dramatically and reliable infrastructural network is developed as a fruit or aftermath of technology puberty. Notably India, among the NICs, conformed to this model, and has enjoyed a high level of industrialization.

The Way Forward

There is always a way out of every situation. A common saying is ‘where there is a will, there is a way’. A typical Nigerian will not accept no for an answer, even when he knows that ‘no’ is no. He will ask ‘what can we do about that’, meaning that there must be a way out. It is this Nigerian spirit of believing that there is a way out of uncanny situations that can be exploited and put to advantage. What other nations did must be studied and applied possibly with modifications to suit our peculiar circumstance.

Nigeria and Industrialization

It should be of note that nations in the West predicate their industries at generating, accumulating and reproducing capital. Import-substitution is the premise of Nigerian industries. To achieve this objective, industrial equipment are imported to Nigeria, installed and used for routine production activities either by multinational corporations, or government sponsored industries. The scenario is that Nigerian Industries are characterized by their inability to revolutionize production.

Manufacturing in Nigeria is characterized by a handful of factories producing construction material, clothing, textiles, footwear and processed foods using simple assembly processes.

Nigerian industries are therefore largely consigned to routine production activities with no backward linkage in the economy. There are in many cases, prevalence of highly-packaged technology, with workers performing only minor operations, lack of ancillary industries, and insignificant or non-existent room for development activities.

Mechanical and intellectual processes are the drivers of technology; consequently industries can be classified according to whether they use mainly materials or knowledge technology. Materials technology is concerned with the type of materials used in the work flow while knowledge technology focuses on the amount, quality, level, sophistication and dispersion of information relevant to decision making and production in an organization.

There is a dominance of materials technology in Nigerian industries work flow. Packaged equipment and other inputs are imported and installed, thereby providing little impetus for the search for sophisticated production information which is the basis of knowledge technology. This is a consequence of import-substitution ideology, an offshoot of ITT. The Nigerian industrialization focuses on mass production of consumer goods and mass production is the product of mechanization. There has been no concerted effort to buy into production of devices that create wealth such as the machine tool.

The effect is the fact that many Nigerian industries are capital intensive, mechanized and assembly line type and the Nigerian scientific and technical workers employed in them experience few of these qualitative elements of utilization. As a result, their intellectual contribution to the production

endeavour is minimal. This cannot provide a basis for any conceivable transformation of the industry. Is it any wonder then that Nigeria with all the vast resources in minerals and crude oil remains poor with about 52% of the population living on less than \$1 (one dollar) per day?

The agent for transformation in the industry is the machine tool industry which is used for creating wealth. Nigeria must strive to enter into the machine tool industry.

Educational exposure

It was my privilege to study in Government College, Umuahia, where the school had workshops equipped with machines for working both metals and wood. The curricular was such that in the first two years of study every student took courses in the workshops. This was my first romance with technical studies. At the University of Nigeria, Nsukka, I was privileged to study where there were machine tools in the workshop that were available for students practice. Is it any wonder that my appetite for production was wetted? At the University of Lagos, there was the Production Engineering laboratory, (apart from the Faculty of Engineering General workshop), which was equipped with standard machine tools, for graduate students use.

THE ODYSSEY IN DESGN AND PRODUCTION

My NIFOR Experience

Palm oil storage tank

The Nigerian Institute for Oilpalm Research (NIFOR), Benin City has the mandate to research and develop oil palms. Prior to the 1970s, it restricted itself to minimal processing of the fresh fruit oilpalm bunches (FFB) it produced. However, in the 1970s, with reducing budgetary allocations from the government, the Institute decided to go into commercial production of palm oil in order to meet up with its growing

financial expenditure. Commercial plantations were blushed and a six ton per hour FFB processing mill was established. The immediate challenge was that the hitherto existing oil storage tank could not cope with palm oil produced. The administration saddled me a newly employed engineer with the design of a 100 ton capacity palm oil storage tank. The task was successfully undertaken and Figure 10 presents the old horizontal palm oil storage tank and the new pair of 100 ton storage tanks.



Figure 10a Horizontal 20 ton palm oil storage tank



Figure10b Vertical 100 ton palm oil storage tank



Figure 10c Man hole for maintenance work

Palm oil processing equipment

After the civil war in 1970, there was a dearth of palm oil processing facilities in the oilpalm belt because the most of the processing facilities installed in the 1960s were now defunct. Palm oil which had been one of the main stays of pre-war Nigerian economy was seriously threatened because the oilpalm farmers could not process their fresh fruit bunches (FFB). In order to stem this tide the Federal Government negotiated with and had a memorandum of understanding with FAO/UNDP for provision of technical support for the development, fabrication and process development of small scale processing equipment. NIFOR was the government agent for executing the project. In 1976, I was recruited as a counterpart staff to the FAO/UNDP Design and testing engineer.

The equipment developed by the project includes a quartered bunch stripper, a fresh fruit bunch sterilizer, a fruit digester, and a crude oil clarifier. These are presented in Figure 11. These equipment have a through put of 0.5 ton FFB/hour; and have been installed throughout the palm belt in Nigeria. Local fabricators produce diverse modified versions and install for processors. In Brazil, Ghana and the Republic of Cameroun replicas these equipment are found. NIFOR has a patent on these equipment.

Integrated digester screw press

At the termination of the FAO/UNDP-NIFOR project the engineer in the Agricultural Engineering Research Division continued developing work on processing equipment. The integrated digester screw press (Figure 12) is one such developed. It features a screw mounted directly under the exit port of the macerated fruit of the horizontal digester. A single electric motor drives both the digester and press screw shaft. A reduction gear attached to the press shaft ensures the right

speed and torque for effective oil expression. This equipment dispensed the use of hydraulic press in the mill, and saves labour needed to move the fruit mash from the digester to the press. The problem of oil leakages from oil seal common to all hydraulic presses was effectively eliminated.



Figure 11a Bunch stripper



Figure 11c Horizontal digester



Figure 11d Fruit sterilizer



Figure 11d Crude oil clarifier



Figure 12 Digester screw press

Speed effect on nut cracking

Nut cracking is an important step in the recovery of palm kernel which constitutes 5 per cent of the palm bunch (Babatunde, 1984). The hard shell of the nut which encloses the kernel varies from 0.4-4 mm for the thin walled palm nuts of the tenera fruit form, and 3-5 mm for the thick walled dura fruit form (Hartley, 1971). Centrifugal nut crackers consist of rotors which hurl nuts against a stationary steel wall. Nut crackers had hitherto been fabricated without recourse to different fruit forms. It became necessary to provide a basis for nut cracker design. (Babatunde and Okoli 1988), theoretically, derived the expression for nut speed for centrifugal nut cracking (equation 2). An experimental rig, (Figure 13), which simulated the potential energy of a falling mass, provided the basis for segregating the hurling speeds of nuts at 30 m/sec for nuts of diameter less than 20 mm, and 26 m/sec for nuts of diameter above 20 mm.

$$v = \sqrt{\left(\frac{dr}{dt}\right)^2 + (wr)^2} \dots\dots 2$$

Where: $\frac{dr}{dt} = aw \sinh wt$ (radial speed)

$$r = a \cosh wt$$

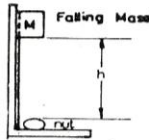

Fig.2. Test rig for palm nut cracking

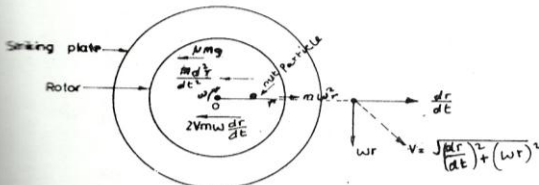
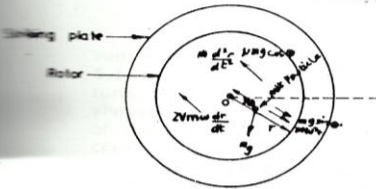

Fig.3. Free body diagram of nut particle in the horizontal rotor of the nut cracker



Air separator for palm kernel/shell mixture

Palm kernel is an economically important by-product of palm fruit (*Elaies guineensis* Jacq.) Processing for palm oil recovery, thousands of tons of palm kernel products are sold in the international market annually, (Green and Lewis, 1987). By 1984 the Nigerian oilpalm industry was producing about 150,000 tons of palm kernel annually (Socfinco, 1984). There are two broad methods of palm kernel/shell separation, the wet

and dry methods. The wet method requires that kernels be sterilized against mould followed by several hours of drying to produce effluent (Gebr-Stork, 1963 and Olie and Tjeng, 1970). The dry method commonly employed in small mills requires hand picking either on trays or on moving belts (Socfinco, 1984). (Babatunde and Okoli 1990), developed a palm kernel/shell separator based on the principles of aerodynamics and pneumatic conveying. The velocity of the air stream in the tunnel is given by equation (3). The system designed and produced for the work is shown in Figure 14.

$$v = \frac{\rho g}{8\mu} b^2 \left[1 - \left(\frac{2x}{b} \right) \right]^2 \quad \dots \quad 3$$

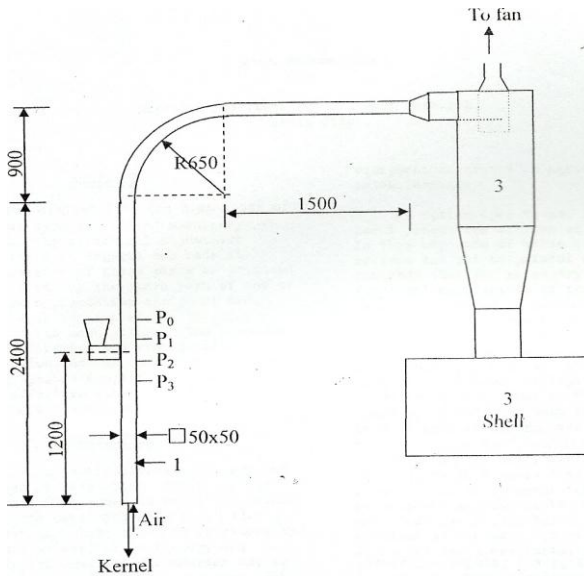

Figure 14 Schematic design of air separator

Factors affecting the efficiency of locally fabricated nut crackers

Nut crackers are of two basic types, the positive impact variety and the centrifugal type. In the positive impact type the nut is impacted as a simulation of the traditional method of the nut placed on a hard surface, whereas in the centrifugal type the nut is hurled at a high speed against a stationary surface. A high incidence of nut kernel splitting characterizes nut crackers made locally. The need to control kernel splitting is determined by the fact that split kernel readily grow mould and develop high free fatty acid content which compromises their quality. (Okoli, 2006) investigated this phenomenon and determined the factors which gave rise to kernel splitting. For the positive impact type, the design parameters for acceptable kernel recovery could be modeled after equation (4). Whereas the model for the centrifugal nut crackers is given by equation (5).

$$P_i = f(c, s, d, h) \quad \dots \quad 4$$

$$P_c = f(v, g, s, b) \quad \dots \quad 5$$

Where; P_i is the performance of the impact nut cracker,
 P_c is the performance of the centrifugal nut cracker,
 c is the clearance between the beater arm and the stud,
 s is the minimum diameter of nut,
 d is height of stud,
 h is the length of exit slot in the cracker ring,
 v is the velocity of the nut,
 b is t clearance of the rotor channel from cracker wall,
 g is diameter of rotor inlet opening.

Figures 15 and 16 elucidate these factors.

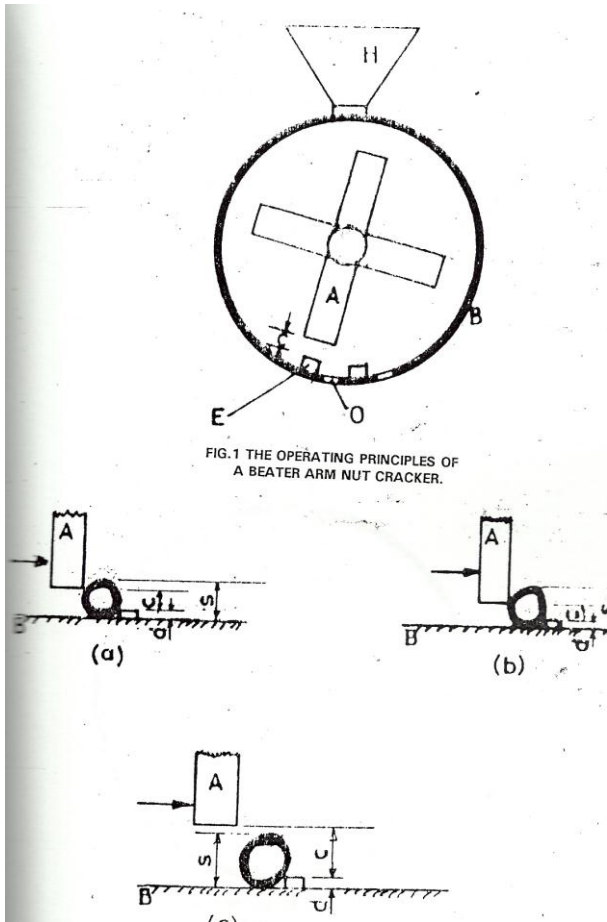

Figure 15 Design factors for impact nut cracker

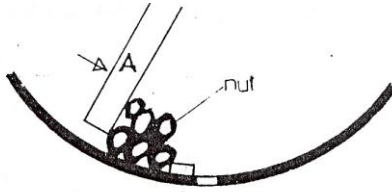

FIG.3 BUNCHING AND LOSS OF WEDGE EFFECT IN A BEATER ARM NUT CRACKER.

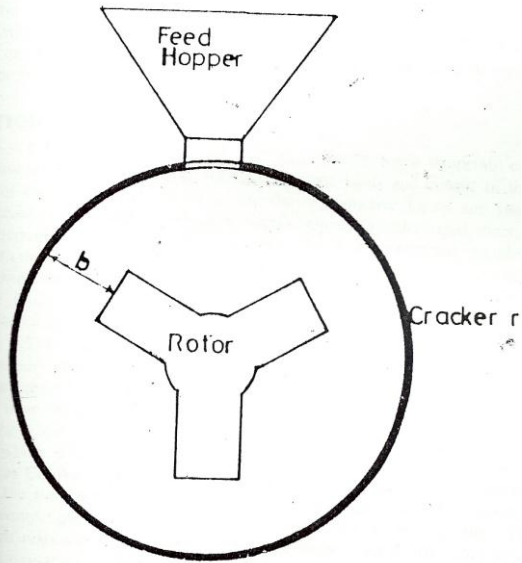

Figure 16 Design factors for centrifugal nut cracker

Highlights of the uses of palm kernel shell

Palm kernel shell, a solid waste product of palm kernel process, is known to constitute 20 per cent of fresh fruit bunch (Babatunde, 1984). A large scale mill is used to complement wood for firing the furnace for steam generation, but it combines with silicon to form linkers on furnace wall. It is also used as filler for pot-holes in earth roads, but a larger bulk lays waste near palm oil processing environment and is usually incinerated; this pollutes the environment with choking and offensive smoke. Okoli (2006) documents the findings of his research team on the end products of the pyrolysis of palm kernel shell using a device, Figure 17, designed and constructed for destructive distillation of kernel shell. The kernel shells were pyrolysed at a temperature of 300°C. The products were pyrolygneous liquor 37.3%, charcoal 33%, settled tar 8.7%, gas (flammable) 24% and charcoal 33% (Babatunde et al, 1989). The rectified pyrolygneous liquor yielded a clear colorless liquid which had selective herbicidal activity on broad leaf weeds (Ikuenobe, 1991). Okoli (1991), reported that the resulting kernel charcoal generates neat and smokeless fire, and when activated with tetraoxosulphate (VI) acid had good bleaching activity on red palm oil. The germicidal activity of pyrolygneous liquor was also reported (Aisagbonhi et al 2002). The use of kernel shell by rural dwellers for flooring of earth houses is therefore commendable.

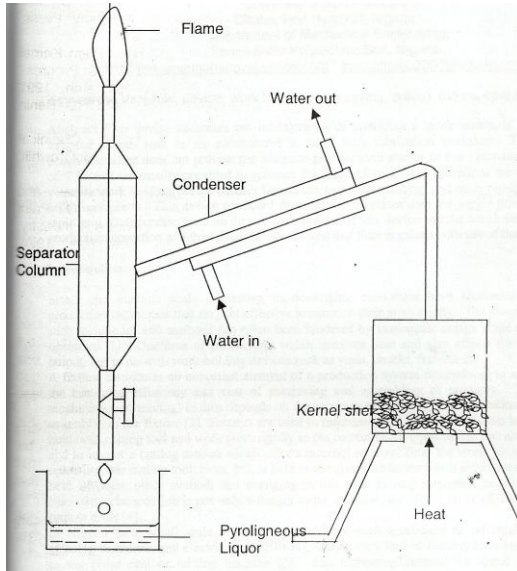

Figure 17a Schematic distilling

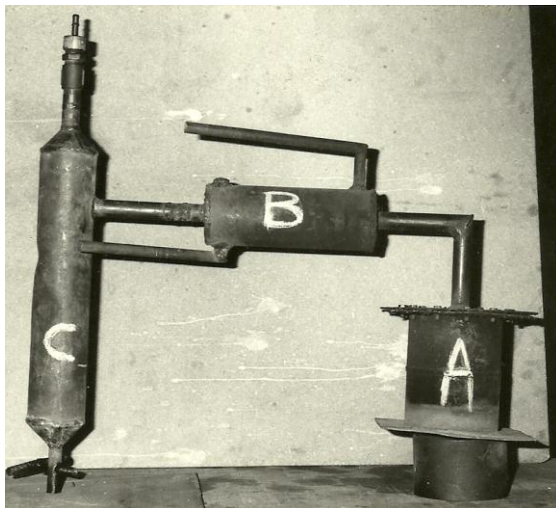

Figure 17b Picture distilling

WORK ON PRESS TOOLS AND RELATED AREA

Production activities on sheet metals which include bending, cutting, forming, stretching etc, are largely done by press tool operations. The design and manufacturing quality of press tooling is a vital determinant to successful sheet metal operation. Press tools in form of punch and die are mounted on an industrial press (Figure 18); the downward stroke of the press slide accomplishes the production action required, as the punch forces sheet metal positioned on the die to conform to the shape of the die. Press tools can be used for single operations, such as blanking, punching and bending; however the need to meet high production quantities may justify the use of a combination press tool. This is merely a press tool that incorporates a number of single tools so that, at each stroke of the press, an operation is carried out at each of the stations (Figure 19). A completed part can be obtained at the end of each press stroke, provided the component is not complex. In respect of parts that are elaborate, and cannot be finished in one combination press tool, it would need to be transferred to one or more tool stations, if the transfer is done automatically; the whole installation is called a transfer press. Transfer presses are common in the automotive industry because of the complexity of the components of sheet metal components and the large quantities required. Precision is a primary requirement of press tools and hardened alloy steels are used for their manufacture, as a result they are expensive. Since their productivity is very high, they are ideal for large volume and continuous operation.

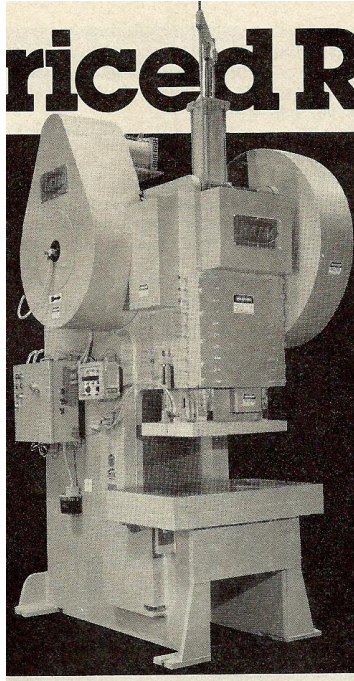

Figure 18 Industrial press

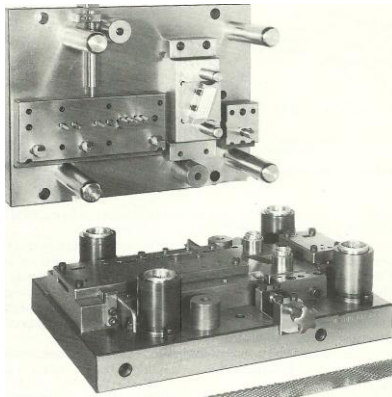

Figure 19 Press tool

Stretch forming experiments for press tool design

The design of press tools for different operations requires; knowledge of the degree of deformation the sheet metal will undergo, the force the press tool needs to exert and the shape of the tool to impart the profile. Okoli and Enahoro (1981) designed and produced a series of punches and dies (Figure 20) with which stretch forming tests were done. A die holder (Figure 21) that housed the punch die was also produced. An Avery tensile testing machine was used to simulate the force and tool motion, micrometer measurements of the specimen thickness before and after each press cycle was the basis of determining the wall thickness ratios of the deformed aluminum test specimen. The relationship obtained for acceptable punch travel punch nose radius was found as in the expression in equation 6.

$$T = 0.406n \quad \dots \quad 6$$

Where; T is the punch travel, and
n is the punch nose radius.

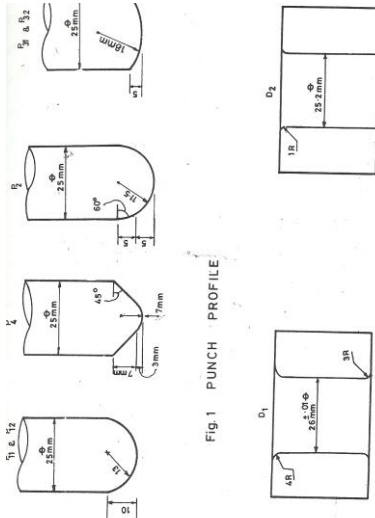

Fig. 1 PUNCH PROFILE

Figure 20 Punch and die

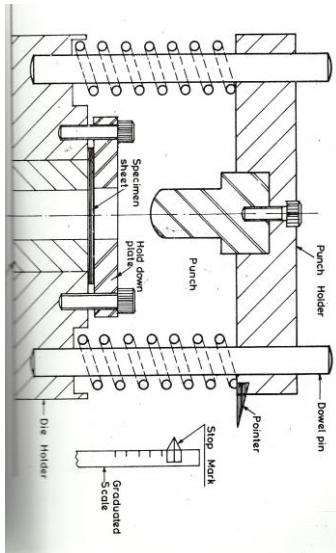

Figure 21 Die holder

This experimental work provided the frame work for the design of a wholly steel fabricated industrial press, Figure 22, which was used for the production of splaid (Figure 23), a spoon-fork utensil for picnickers.

The industrial press was produced with materials wholly purchased in the Nigerian market. In carrying out the project, the University of Lagos negotiated with the authorities of the Nigerian Railways Corporation, Lagos and Metal Box-Toyo Glass Company, Lagos in order to enable me do four months attachment with each of these establishments. The exposure enabled me to acquire competence in production processes and press tool operations.

Positive angular teeth clutch

Industrial presses are high productivity equipment and in their operation, stop and start actions are necessary. The electric motor drives are coupled to the press drive shaft through clutch mechanisms which enable engagement/ disengagement of the press slide. Efficient operation of the clutch mechanism is crucial to the performance of a press. There are different types of clutch mechanisms. In the design of the industrial press discussed earlier, appositive angular teeth clutch was the preferred option, given the Nigerian condition. The design and production challenges encountered in the course of developing the clutch is discussed in Okoli (2005). It required the design and production of a jig to enable use of a shaping machine to cut the teeth profile, since there were no other gear production facilities available. The position of the clutch in the press is presented in Figure 24.



Figure 22a Front view of industrial press



Figure 22b Rear view of industrial press



Figure 23 Spaid- spoon- fork combination

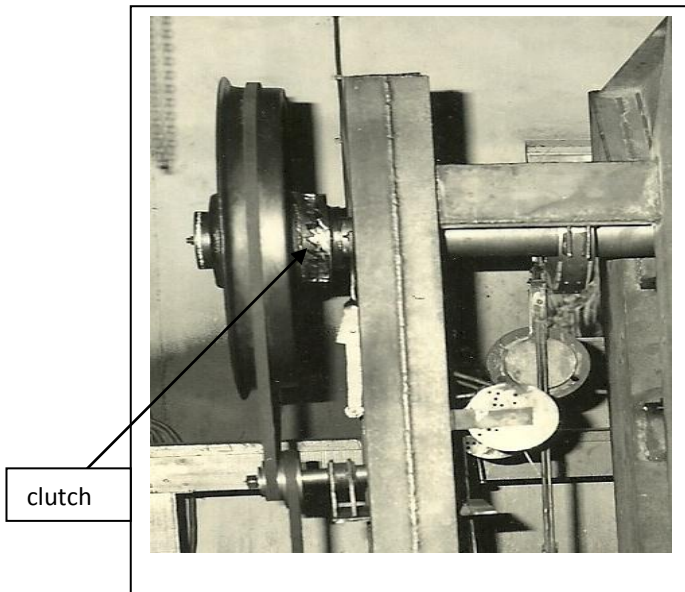

Figure 24 View of press with clutch

Kitchen knives

Kitchen knives in the Nigerian markets are majorly of two kinds, the imported or locally made. Imported brands are made of either stainless steel or medium carbon steel. Local brands are produced from mild steel plates, and are fraught with corrosion and quick blunting of the cutting edge with usage. Mild steel is more readily worked than superior grade of steels, the higher grades of steels are expensive (Dallas, B., 1976) and suitable machinery for working them were not available locally (UNIDO, 1979). At this time, there were dynamic lumbering activity for furniture and building purposes, as a result band saws used for slitting wood trunks were being frequently replaced; and these are medium carbon steel. A design of a mini press tool (Figure 25) was made of a punch press assembly to produce kitchen knives from these discarded band saw blades that littered waste dump sites around wood saw mills Benin City metropolis (Okoli, 1994).

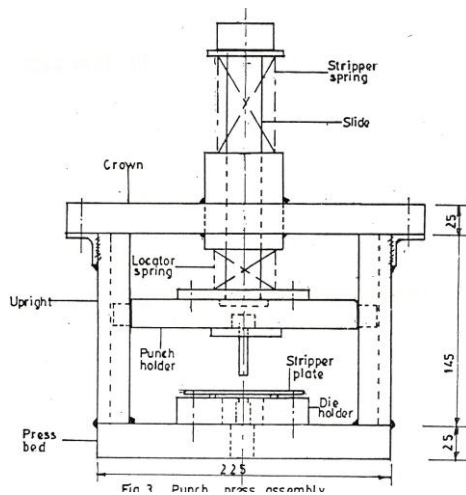

Figure 25 Press tool for kitchen knife

OTHER WORKS

Coal gasifier reactor

Coal gasifier, otherwise industrially known as combustor, is a vessel in which coal reacts with moving fluid such that the coal is oxidized or burnt during fluidization process. Coal fluidization where air or oxygen is used is regarded as gasification. Coal gasification may operate under pressure (above 10 atmospheres in bed depth of 1 m and above) while others may be carried out at 1 atmosphere in a bed depth of between 0.5 m-1.5 m (Maier, 1994; Adeyinka, 1997). Adeyinka and Okoli (2002), designed a gasifier that was suitable for both Bituminous and Lignite coal at an experimental level. It only remains for appropriate parameters for scale up to be adopted to produce large-scale industrial gasifier for drying, power generation or even utility power generation. Locally available materials can be exploited in the production of such a gasifier.

Ownership/apprenticeship disposition in fabrication shops

Manufacturing in Nigeria can be grouped in three broad categories namely; traditional manufacture, manufacture employing modern equipment, tools and processes which is on small and medium scale, and large scale manufacture. The second category of manufacturers is more pervasive. This group is made up of semi-skilled, skilled, technical, technological and engineering personnel. This group can be further divided into two; the first being workers who operate highly limited tools and are commonly referred to as road-side fabricators. The common equipment at their disposal are welding machines, hand grinding machines and limited fitting tools. The other sub group consists of well housed workshops in limited space, and possess one, two or more machine tools such as, a lathe, pedestal drill, power saw or miller along with

other fabrication equipment and fitting tools. This latter category of manufacturers produces the widest range of goods spanning house hold articles- knives, stoves, seed grinders etc; office equipment such as cupboards, executive chairs etc, to industrial and agricultural processing machinery such as life stock mills, garri and oil palm fruit processing mills, etc. This group engages in copy technology and also produces spare parts of equipment. However they have two fold weakness; they hardly engage in product design and the finish of their products lack finesse. In an attempt to find account for these underlying weaknesses a study was undertaken to study the educational qualifications of the proprietors/managers apprentices in these workshop (Okoli, 1999). The data in Table 1 is revealing. The fact that only 2.53 per cent of these establishments are owned or managed by qualified engineers explains their inability to undertake simple designs, and also impact on the level of appreciation of quality. It becomes obvious that the quality of skill that can be imparted to the apprentices would be low. This vicious cycle would continue, until there is a deliberate injection into this group of manufacturers, qualified and value oriented engineers. A possible reason for the low presence of engineers in this group could be inadequate grounding in design capability while at school.

Table 1 Data on educational background in small- workshops (per cent)

Education Personnel	Non OND Formal MSc	Primary HND six	JSSC BSc/BEng/	SSSC	Technical School
Proprietors and Managers	17.60	45.7	-	6.96	13.29
Apprentices	4.50	35,59	15.69	17.96	25.4

Petroleum products pipeline security

Pipelines facilitate the processing and transportation of liquid and gas hydrocarbons from production points to end users who could be at distance of thousands of kilometers. Pipelines have remained central to the economic growth of Nigeria. About 10,480,533 metric tons of petroleum products were evacuated mainly through pipelines in 2002 (NNPC). Pipelines in Nigeria have been fraught with failures with consequent negative impact both on the economy and the environment. These failure occurrences have been attributed to several causes (Mohitpour et.al. 2002, Okoli and Akhigbemidu, 2003). Recent studies attribute failure to deliberate human intrusion (Ogbeifun, 2007; Walker, 2008; Yo-Essien, 2008). In order to proffer a viable solution to pipeline intrusion it is necessary to have an early warning of intruding activities. Akhigbemidu and Okoli (2011) have developed a method of discrete sensors to extract modal coordinates/velocities/accelerations of pipelines which assist in determining when and where activity

is taking place on a given pipeline. This is a promising and potential approach to solving the problem of pipeline intrusion. It is left to pipeline asset owners to buy into this new development.

Processing of beans cake

Cowpea (*Vigna Unguiculata*) commonly known as beans is grown in the tropics and sub-tropics as a vegetable, legume or fodder (Sybit, 1994). In Nigeria beans is processed and used for preparing beans cakes as ‘moi-moi’, ‘ekuru’, ‘akara’ etc. The processing of beans for these delicacies is be-riddled with stress at the stage of de-hulling or removal of the seed coat. The other aspects of processing have long been mechanized. Okoli et al. (1998) developed a device for beans de-hulling (Figure 26), which could either be manually operated for home applications or motorized in case of large volume production for beans de-hulling. This device, Figure 26, is cost effective, neat in application, time and energy saving,

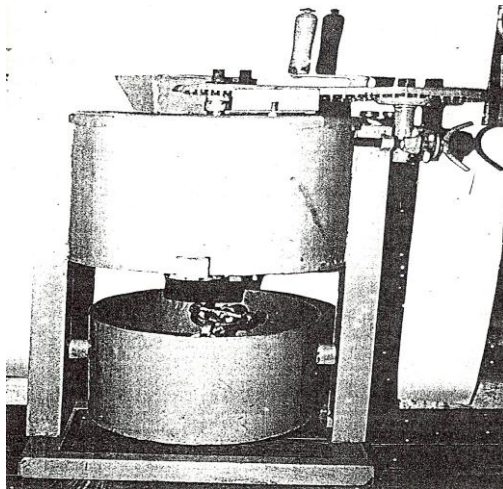

Figure 26 Beans de-hulling device

Globalization

Globalization means greater integration and competitiveness among all states. In simple terms, it means trading without any borders. This simply assumes that all nations are on equal pedestal and so there will be fair competition. But is this true? Economic comparisons can be made by looking at the statistical tables or indices of what goods and services are produced and used in the societies under the consideration. The national incomes of countries and the national income per capita are in the common domain of the layman. Consider the data presented in Figures 27, 28, and 29; it immediately becomes apparent that there is no fairness amongst nations.

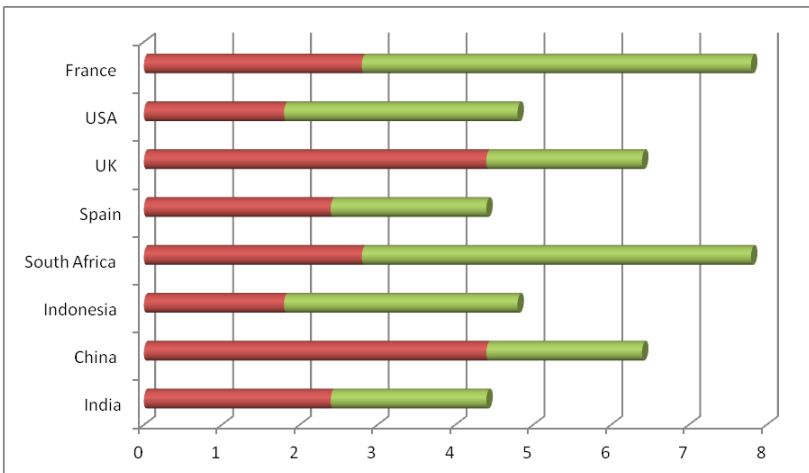

Figure 27: GDP per capita in 1992 for countries with a GDP in excess of £50 000 million (World Bank 1994)

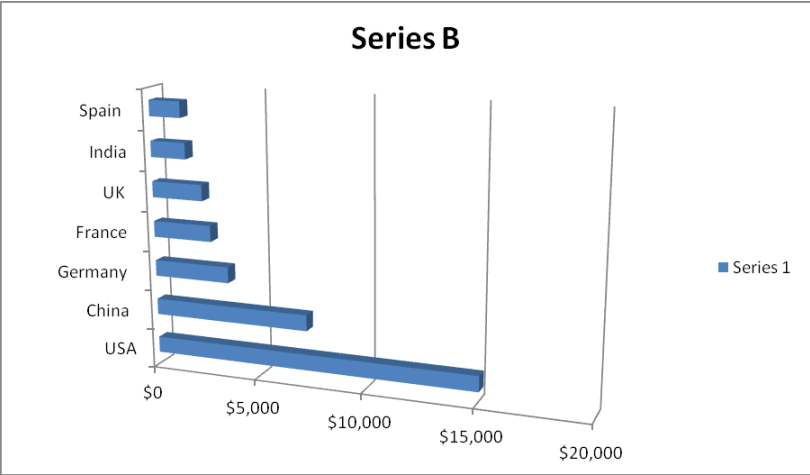

Figure 28: Largest Economies by nominal GDP 2011 (\$billions)

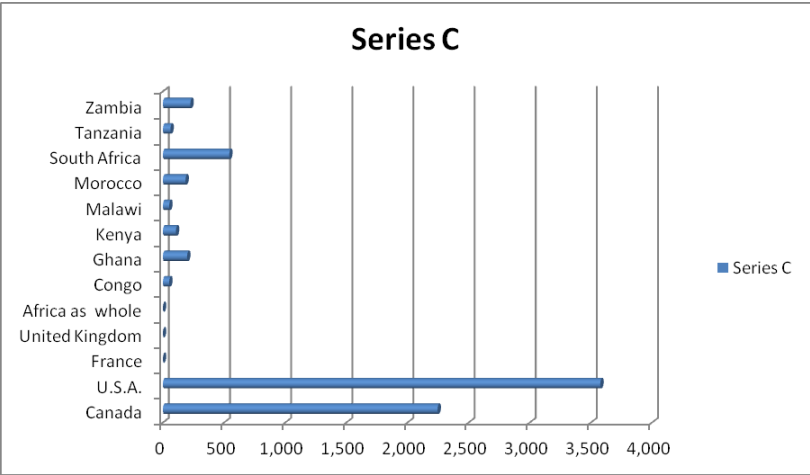

Figure 29: Statistical UN publication 1968

Globalization is a doctrine invented to keep the less productive nations ever dependent on the more technological advanced nations. Consider the brother of globalization, International Technology Transfer (ITT), how much technology has been transferred to African nations over these past years. Are we feeling the impact? Unless the developing countries (DVCs) take practical measures to transform their economies by boosting their exports, their share of world trade and exports would continue to fall.

What can be done?

The steps that must be taken to move away from DVC to NIC category include:

- Establishment of metal and wood workshops to train up youths on simple workshop practice and processes at the primary and secondary levels.
- Retraining teachers in phases on technical skills.
- Stock taking of investment committed to technical education over the past years to ensure that future investments are properly utilized
- Establishment of a proper monitoring team with authority to sanction schools found to default in the commitment to teaching technical courses.
- Provision of subsidy by the Government to private and public schools to put up appropriate workshops.
- Commitment to proper funding of engineering and technology programmes in higher institutions.
- Establishment of functional workshops in tertiary institutions where students will freely operate the machines themselves.
- Finance of undergraduate projects in engineering through the TET government fund.

CONCLUSION

Vice Chancellor, Sir, the Holy Bible in 2 Corinthians 9 verse 6 reads ‘But this I say: “He who sows sparingly will also reap sparingly, and he who sows bountifully will also reap bountifully”’. People who aspire to be great, deliberately and with determination work to attain that goal, the lazy only wish but since wishes are not horses, they never ride to success.

Similarly ‘production’ is deliberately groomed by people who apply themselves to acquisition of technology through discipline, hard work, well thought and planned investment in time and money, with the knowledge that at the end of the tunnel there awaits for them skills and abilities to turn out goods needed by society to meet home, office community, military and diverse needs with which they can, as God mandated man, ‘subdue and dominate the environment’ and so gain freedom.

VC, Sir, any nation that desires to be reckoned with, must take its destiny in its hands and work towards acquiring technology, so that its production can grow otherwise it will be a pun and so remain in bondage. Production is a destiny we have and can manipulate for our freedom or bondage.

Thank you very much for coming, sitting down and listening to me. May God bless you all richly and grant to each of you safety to your various homes.

REFERENCES

- Abramowitz, M., (1956) Resources and output trends in the United States since 1870, American Economic Review, Papers and Proceedings, May.
- Adeyinka, J. S. (1997). Gasification of Nigerian Coal in Shallow beds. PhD Thesis, Mechanical Engineering Department , Federal University of Technology, Minna, Nigeria.
- Aisagbonhi, C. I., Appiah, F. O., Okoli, J. U. , Oshomo, E. O. and Kolade, K.O, (2002) Investigations on the Termicidal Activities Palm Kernel Shell Extract, Occasional Publication of the Entomological Society of Nigeria, No.34, pp.61- 65.
- Akhighbemidu, C. C. and Okoli, J. U. (2011); Single Beam Model for Predicting Intrusion in Pipelines, Ife Journal of Technology, Vol. 20, No. 2; pp 36-45.
- Babatunde, O. O. (1984). Development and Testing of low cost processing procedure for palm oil. Unpublished MSc. Thesis, University of Ife.
- Babatunde, O. O. and Okoli, J. U. (1988). Investigation into the effect of Nut Sizes on the Speed Needed for the Cracking of Nuts in Centrifugal Nut Crackers. Nigerian Journal of Palms and Oil Seeds. Vol. 9. Pp 94-108.
- Babatunde, O. O., Okoli, J. U. and Ikuenobe, C., (1989), End Uses Potential of Palm Kernel shell, International Conference on Palms and Palm Products, Benin City.

- Babatunde, O. O. and Okoli, J. U., (1990). Design and Construction of an Air Separator for Palm Kernel/Shell Mixture. 14th Annual Conference of the Society of Agricultural Engineers, University of Makurdi 12-15 September.
- Baldwin, L. D. (1969) The Stream of American History, Fourth Edition, Van Nostrand Reinhold Co., New York.
- Baldwin, L. D. (1969) The Stream of American History, Fourth Edition, Van Nostrand Reinhold Co., New York.
- Bartlett, I. E., Fenton, E., Fowler, D. and Mandelbaum (1969) A New History of the United States: An Inquiry Approach, Holt Social Curriculum, Holt, Reinhard and Winston Inc. New York.
- Blanchard, B. S and Fabrycky, W. J. (2006) Systems Engineering and Analysis 4th Edition. Prentice Hall International New Jersey P11
- Cardwell, D. S. L., (1974) Turning Points in Western Technology: A Study of Technology, Science and History, Science History Publication, New York.
- Carrington, C. E and Jackson, J. H. (1954) A History of England, Cambridge University Press, England.
- Carrington, C. E and Jackson, J. H. (1954) A History of England, Cambridge University Press. England.
- Chestnut, H. (1965). Systems Engineering Tools, Wiley, New York.

- Cobb, C. and Douglas P(1928)A Theory of Production, American Economic Review, Supplementary, March.
- Dallas, D. B., (1976) Tool and Manufacturing Engineers Handbook, 3rd Edition. McGraw Hill Book Company New York. Pp 37-1
- Dallas, D. B., (1982a) Industry in the Depression 1932-1939, Manufacturing Engineering, Vol.86, No.1 pp 37-78
- Dallas, D. B., (1982b) Industry at War 1940-1945, Manufacturing Engineering, Vol.86, No.1. pp 79-114
- Davies, R. T. (1969) Documents Illustrating the History of Civilization in Medieval England 1066-1500, Methuen & Co Ltd. London.
- Davies, R. T. (1969) Documents Illustrating the History of Civilization in Medieval England 1066-1500, Methuen & Co Ltd. London.
- Dent, H. C. (1975), The Educational System of England and Wales, UNIBOOKS, University of London Press Ltd. Second Impression, London.
- Eyo-Essien, L.P. E. (2008) Oil Spill and Management in Nigeria: Challenges of Pipeline Vandalism in the Niger Delta Region Nigeria . National Oil Spill Detection & Response Agency (NOSDRA),Nigeria.,Retrievedfrom,<http://ipcc.utulsa.edu/Conf2008/Manuscripts%20~%20presentations%20received/EyoEssien2pdf> Accessed in Nov.2009.

- Gosling, W. (1962). The Design of Engineering Systems, Heywood. London.
- Green, S, and Lewis, P. (1897). Oil and Fats. International Trade Publication Ltd. Survey
- Gregg, P. (1971) a social and Economic History of Britain 1760-1970, Sixth Edition Revised, Georg G Harrap and Co. Ltd, London.
- Hartley, C. W. S. (1971). The Oil Palm. Longmans Group Limited. London. P 242.
- Hartwig, G. N. (1982) Electronic Control Moves into the Ascendancy 1960-1969, Manufacturing Engineering, Vol.86, No.1.pp181-202
- Hunter, Louis C.; Bryant, Lynwood; Bryant, Lynwood (1991), A History of Industrial Power in the United States, 1730-1930, Vol. 3: The Transmission of Power, Cambridge, Massachusetts, London: MIT Press, [ISBN 0-262-08198-9](https://doi.org/10.1017/CBO9780511524444)
- Ibhadode, A. O. (1997). Introduction to Manufacturing Technology. Ambik Press, Benin City.
- Ikuenobe, C., (1991). Evaluation of the Herbicidal Potential of Pyroligneous Liquor, Progress Report on Palm Oil Programme. In-House Research Review, NIFOR, Benin City.
- Johnstone, O. B. (1985) Sharing the Cost of Higher Education, College Board Publications, New York.

Maier, W. F. and Franke, K., (1994) Methanopyrolysis of Coal Fuel. Vol.73, No. pp 510.

Mohitpour, M. Golshan, H. and Murray, A. (2000). Pipeline Design and Construction – A Practical Approach, ASME Press, New York.

Nigerian National Petroleum Company, (2002 -2008). Annual Statistical Bulletin.

Ogbeifun, B. L. (2007). Effects of Petroleum Pipeline Vandalism on Society, Employee and Organizational Productivity: The Dilemma of Downstream Operations in Nigeria. Retrieved from <http://Louisbrownogbeifun.com/?p=39>. Accessed in November, 2009.

Ogbimi, F. E. (2004) Understanding Why Learning is the Primary Source of Growth, Industrialization and Development, Society for Linking Education and Problems Publication. Obafemi Awolowo University, Ile Ife, Nigeria.

Ogbimi, F. E., (2010) Building Science, Technology, INNOVATION (STI) AND ENGINEERING Capabilities in a Developing Nation, Proceedings of the National Workshop on Strengthening Innovation and Capacity Building in the Nigerian Manufacturing Sector held at Sheraton Hotel and Towers, Lagos, 20th – 21st July. PP Proceedings of the National Workshop on Strengthening Innovation and Capacity Building in the Nigerian Manufacturing Sector held at Sheraton Hotel and Towers, Lagos, 20th – 21st July. PP 74-85

- Okoli, J.U. and Enahoro, H.E. (1981) Optimum Conditions for Stretch Forming, *he Nigerian Engineer*, Vol. 16, No. 4; pp 16- 28.
- Okoli, J. U., (1991). Palm Kernel Charcoal, 1989/90 Progress Report, End-Use Research, 1991 In-Research Review, NIFOR, Benin City.
- Okoli, J.U. (1993) Some Factors Affecting the Efficiency of Locally Fabricated Palm nut Crackers. *The Nigerian Production Engineer*, Vol. 1. No. 2 pp 13-19.
- Okoli, J. U. (1994) The Design and Construction of a Manually Operated Punch Press for Small Scale Production of Kitchen Knives, *Proceedings of the Second Africa-USA International Conference on Manufacturing Technology*, Lagos, pp 82-90.
- Okoli, J. U. (1997). *Fundamentals of Mechanical Engineering Design*, A Monograph Johnny Associates, Port Harcourt.
- Okoli, J.U. (1998) Appropriate Design Training: A Vehicle for better Quality Nigerian Made Product, *First National Engineering Design Conference*, 26-29 Sept, Abuja, 1999.
- Okoli, J.U. and Okpala A. and Eyeoyibo D, (1998) Design and Fabrication of a Manually operated Soaked Beans Dehulling Machine; *Proceedings of the 2nd National Conference of NIProdE*, Benin City.
- Okoli, J.U. and Akhighbemidu, C.O.(2003) *Failure Prevention Strategies in Pipeline Operations in the*

- Okoli, J. U. (2005) Positive Angular Teeth Clutch – An Alternative Production Process Using a Jig and a Shaping Machine, International Research Journal in Engineering , Science and Technology; Vol.2. No.2 pp 112-123.
- Olie, J. J. and Tjeng, T. D. (1970)Some Notes on the Treatment and Disposal of Palm Oil Mill Effluent. Stork Amsterdam, Holland. 1-21.
- Parker, S. P., (1989) McGraw-Hill Concise Encyclopedia of Science and Technology 2ed. McGraw-Hill Book Co. New York. P.18498.
- Socfinco (Socfin Consulsultancy Services, Belgium) (1984). Technical Report of Feasibility Study on Nigerian Oil palm milling Programme. Federal Department of Agiculture. 96-98
- Solow, R. (1957) Technical Change and the Aggregate Production Function Review of Economic and Statistics, August.
- Thirlwall A. P. (1972) Growth and Development with Special Reference to Developing Economies, The Macmillan Press, Bunglay, Suffolk, England.
- Trevelyan, G. M. (1948) History of England, Longman Green Co., London.
- Turner, W.C., Mize, J. H. and Case, K. (1978), Introduction to Industrial and Systems Engineering, Prentice-Hall, Englewood Cliffs New Jersey. Pp 3-9

UNIDO, (1979). Appropriate Industrial Technology-Agricultural Machinery and Implementation, Monograph on appropriate Industrial Technology, No.4, United Nations.pp 1-11.

Vasilash, G.S, (1982) The Advent of Numerical Control 1951-1959, Manufacturing Engineering, Vol.86, No.1.pp 143-172.

Wikipedia (June 2012) Machine tool [www//http.wikipedia](http://www.wikipedia)

Woodson, T. (1966). Introduction to Engineering Design. McGraw-Hill, New York.

CITATION ON
PROF. JOHN UMUNNA OKOLI

BSc (*Nigeria*), PhD (*Lagos*), MNSE, MNiProDE, MNIEM, ASME



Birth and Education

Professor John Umunna Okoli was born at Uyo, capital of Akwa Ibom state on 18th November 1947 to Mr. John Umegboro and Mrs. Belinda Mgbonbgo Okoli (of blessed memory), of Ajalli, Anambra State. He completed his primary school education with distinction at Government Primary School, Uyo, in 1961. His Secondary School education was at Government College, Umuahia where in 1966 he obtained the West African School Certificate grade one. His Higher School Education at Government College Umuahia, was truncated by the civil war in 1967. He returned to Umuahia, briefly, in March, 1970 and left in October 1970 for the University of Nigeria, Nsukka to study Mechanical Engineering. He was a Shell scholar. He graduated with a Second Class Upper honours, Bachelor of Science degree in 1975.

At Umuahia, he was a member of the Fine Arts Club and presented paintings for exhibition during parents' day activities. From 1963 to 1965 he was in the School Physical

Education Squad which thrilled the audience at the college parents' day celebrations with gymnastics.

His higher degree studies at the University of Lagos, where in 1988; and he obtained the Doctor of Philosophy (PhD) degree in Mechanical Engineering. He was sponsored by the Nigerian Institute for Oilpam Research (NIFOR).

Professional career

Professor Okoli is professionally registered as an engineer with Council for the Regulation of Engineering in Nigeria, (COREN) and has served the profession in diverse capacities. From 1991 to 1995 he represented the Nigerian Society of Engineers (NSE) in the Edo/Delta State Panel of the Federal Ministry of Mines, Power and Steel for the Licensing of Electrical contractors. He served in the Seminar Committee of the NSE, Benin City chapter, from 1991 to 1994. This group organized workshops and short training sessions on behalf of the professional body. Okoli was the Technical Secretary of the Nigerian Institution of Production Engineers (NIProdE) 1992 to 1998. This office was responsible for conferences and publications. In 2004 he was appointed a reviewer for the NSE journal. He served as examiner for COREN, from 1993-1995, for the registration of professional registration. He represented COREN in the accreditation panel to Cross River State College of Technology, Auchi Polytechnic and Kwara State Polytechnic in 1998, 2001 and 2005 respectively. Okoli served in the Committee of Deans of Engineering and Technology (CODET), an advisory arm of COREN from 2009 to 2011.

Positions of Responsibility Held

Professor Okoli has held several positions of responsibility in the Nigerian Institute for Olipalm Research (NIFOR) and in the University of Port Harcourt. Only a few will be highlighted. Professor Okoli is known for his positive and

result oriented contributions when issues are discussed, and brings innovation to any office he occupies. Whilst at NIFOR he was appointed Assistant Programme leader, End Use Research Programme from 1989 to 1994. In this capacity he was the leader of the Engineering Research Team. As Acting Head, Department of Mechanical Engineering from 1995-1997, he introduced photo album for all students to check examination malpractice. Students at entry into final year were made to see the spreadsheet of all previous results. When in office as Coordinator Post-HND-Bachelor of Engineering Degree Unit from 1997 to 2002 he restructured the academic content to make it comprehensive. As coordinator of the course Engineering Drawing he introduced three hours practice class each week for all students, and with approval of the Dean, Engineering and University administration every student was made to have all the equipment for the course. This step turned the failure rate in the course from seventy percent to a pass rate of about eighty percent. During his tenure as Dean, Faculty of Engineering, (2009-2011) he made provision for snacks to encourage invigilators of faculty wide courses and provided logistics support for the Faculty Examinations Monitors. He provided solar powered lighting for the faculty offices to cushion the effect of endless power outages. He set in motion the machinery for the acquisition of lap top computers solely dedicated for results computation. He got the support of the administration for funds so that five programmes of the faculty obtained full accreditation from the professional body COREN. He organized one day training session for newly recruited staff in the faculty. In 1998 he was Chairman of the Faculty of Engineering Ad Hoc Committee for the Renovation/Expansion of the Engineering Drawing Studio in preparation for preparation for COREN accreditation. He served in the School of Basic Studies Examination Committee from 2000 to 2006. It is on record that

this committee radically restructured the modus operandi for conducting examinations; the University is still reaping the benefits of the work of that committee. He was the Acting Director, Science and Engineering Workshop from 2005 to 2006. From 2001 to 2002, he served as Senate Representative in the Board of College of Continuing Education and Development Committee, University of Port Harcourt. He has been Chairman, Departmental Graduate Studies Board from 2004 to 2006 and 2009 to date. He served in the University Degree Results Verification Committee from 2005 to 2006 and as the Dean, Faculty of Engineering he was a member of the Board of the School of Graduate Studies. In 2011, he was appointed Director, Offshore Technology Centre, UNIPORT.

National and Community Service

Professor Okoli served as consultant to Decorwood Nigeria Limited from 1985-1988 for the development of kaolin pulverizes for a factory at Ukpok, Anambra State and Calabar Cement Factory; and to Integrated Systems Nigeria Ltd, for the development of small scale processing equipment for diverse applications. In 1991, he was Consultant to Raw Materials Development Council for the Audit of Indigenous Technologies for the Processing of Raw Materials in Edo, formerly Bendel and Rivers States. In 1990, he was Consultant Agriculture Development Programme for the assessment of the activities of Women in Ogun State involved in oil palm fruit processing. He served as consultant to Anambra State Cooperative Union for the Assessment of Isulo Garri Processing Industry.

Professor Okoli has served as external examiner to: University of Benin 2010, Rivers State University of Science and Technology 2004-2007, Federal University of Owerri 2002-2006, 2009-2012, University of Nigeria Nsukka 2010-2011, and University of Lagos 2010-2012.

Research Interest and Publication

His research interest is centered on development of small to medium scale equipment for diverse applications and on methods for enhancing productivity. He has worked on many developmental projects and was at the core of the development of the horizontal digester which has brought great relief to the small to medium scale oil palm fruit processors. His numerous articles published in journals, local and international, in conference proceedings and as technical reports are of very high standard.

Christian involvement

Professor Okoli benefited immensely from the Bible teachings under Dr Uka who used to gather children on Saturdays for Bible teaching at Uyo from 1959 to 1960. He is involved in Christian activities and was secretary of Scripture Union in 1967. He was one of the five students at the centre of Christian revival at Government College Umuahia, in 1970, during his brief spell at the College after the Nigerian Civil war. At the University of Nigeria, Nsukka he was active in the Christian Union and served as Secretary and President of the Union in the 1972/73 and 1973/74 sessions respectively. He was with the team of Youth Corpers who in December 1974 stormed Zaria city with gospel message. At the University of Lagos, he played an advisory role to Lagos University Christian Union, and co-founded the Christian Staff fellowship in 1980, with the likes of Professors Oyebande and Olu Ayeni. He Served as Council Secretary of Nigeria Fellowship of Evangelical Students (NIFES) from 1979-1985. He was branch Chairman of the Nigerian Christian Graduate Fellowship 1984-1987, and served two terms as a member of the National Executive of the fellowship. He has served the Scripture Union in diverse capacities and is still serving as a member of the Ahoada Area Committee. He is a Lay Reader in the Anglican Communion

and is a teacher of the Holy Bible. He was an active teacher in the Children Sunday School at Nsukka, Lagos and is still actively involved in children ministry. This involvement in children ministry is informed by the knowledge that the formative years of any one have a very strong impact in one's future. "Train up a child in the way he should go and when he is old he will not depart from it" (Proverbs 22:6) is a divine injunction he holds dear to the heart. It is better to build a life than try to mend it when it has gone sour later in life. His Christian counsels has impacted positively on many lives.

Family

Professor Okoli is happily married to Sophia and is blessed with three children, Tochukwu, Chiamaka and Nwachukwu. His conviction is that the home is the bed rock of any society, hence his commitment to seeing that families have peaceful homes. He delights in gardening, reading and wood carving.

Conclusion

Mr Vice Chancellor, Sir, distinguished ladies and gentle men, it is my honour, privilege and pleasure to present to you, our 90th inaugural Lecturer, a man of disciplined disposition, an accomplished engineer, an academic, a lover of children, a willing disciple of Jesus Christ a man who has rendered positive service to this University and to mankind – Professor John Umunna Okoli.

Thank you.

Professor Anthony Ogbonnaya Ibe